



National
Qualifications
2024

X857/76/12

**Physics
Paper 1 — Multiple choice**

THURSDAY, 25 APRIL

9:00 AM – 9:45 AM

Total marks — 25

Attempt ALL questions.

You may use a calculator.

Instructions for the completion of Paper 1 are given on *page 02* of your answer booklet X857/76/02.

Record your answers on the answer grid on *page 03* of your answer booklet.

Reference may be made to the data sheet on *page 02* of this question paper and to the relationships sheet X857/76/22.

Space for rough work is provided at the end of this booklet.

Before leaving the examination room you must give your answer booklet to the Invigilator; if you do not, you may lose all the marks for this paper.



* X 8 5 7 7 6 1 2 *

DATA SHEET

COMMON PHYSICAL QUANTITIES

Quantity	Symbol	Value	Quantity	Symbol	Value
Speed of light in vacuum	c	$3.00 \times 10^8 \text{ m s}^{-1}$	Planck's constant	h	$6.63 \times 10^{-34} \text{ Js}$
Magnitude of the charge on an electron	e	$1.60 \times 10^{-19} \text{ C}$	Mass of electron	m_e	$9.11 \times 10^{-31} \text{ kg}$
Universal Constant of Gravitation	G	$6.67 \times 10^{-11} \text{ m}^3 \text{ kg}^{-1} \text{ s}^{-2}$	Mass of neutron	m_n	$1.675 \times 10^{-27} \text{ kg}$
Gravitational acceleration on Earth	g	9.8 m s^{-2}	Mass of proton	m_p	$1.673 \times 10^{-27} \text{ kg}$
Hubble's constant	H_0	$2.3 \times 10^{-18} \text{ s}^{-1}$	Speed of sound in air	v_{air}	$3.40 \times 10^2 \text{ m s}^{-1}$

REFRACTIVE INDICES

The refractive indices refer to sodium light of wavelength 589 nm and to substances at a temperature of 273 K.

Substance	Refractive index	Substance	Refractive index
Diamond	2.42	Water	1.33
Crown glass	1.50	Air	1.00

SPECTRAL LINES

Element	Wavelength (nm)	Colour	Element	Wavelength (nm)	Colour
Hydrogen	656	Red	Cadmium	644	Red
	486	Blue-green		509	Green
	434	Blue-violet		480	Blue
	410	Violet	Lasers		
	397	Ultraviolet	Element	Wavelength (nm)	Colour
	389	Ultraviolet	Carbon dioxide	9550 } 10590 }	Infrared
Sodium	589	Yellow	Helium-neon	633	Red

PROPERTIES OF SELECTED MATERIALS

Substance	Density (kg m^{-3})	Melting point (K)	Boiling point (K)
Aluminium	2.70×10^3	933	2623
Copper	8.96×10^3	1357	2853
Ice	9.20×10^2	273
Sea Water	1.02×10^3	264	377
Water	1.00×10^3	273	373
Air	1.29
Hydrogen	9.0×10^{-2}	14	20

The gas densities refer to a temperature of 273 K and a pressure of $1.01 \times 10^5 \text{ Pa}$.

Total marks — 25
Attempt ALL questions

1. A cyclist travelling along a straight track accelerates at 1.2 m s^{-2} .
The speed of the cyclist increases from 4.0 m s^{-1} to 7.5 m s^{-1} .
The distance travelled by the cyclist during this acceleration is
- A 1.5 m
 - B 17 m
 - C 20 m
 - D 30 m
 - E 34 m.

[Turn over

2. A ball is thrown vertically upwards and returns to its original position.
Neglecting air resistance, which displacement-time ($s-t$) graph represents its motion?

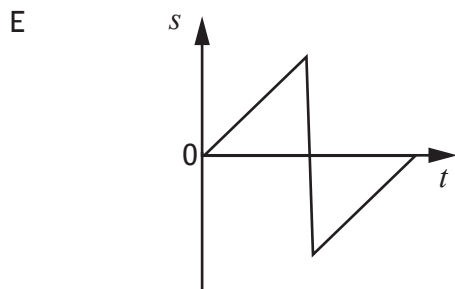
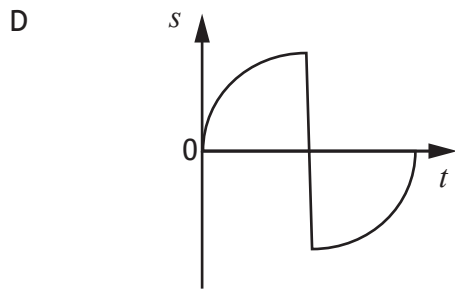
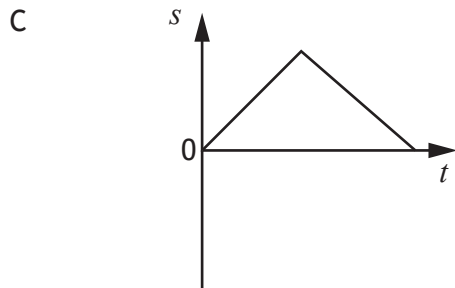
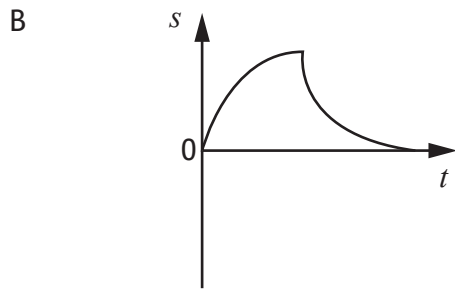
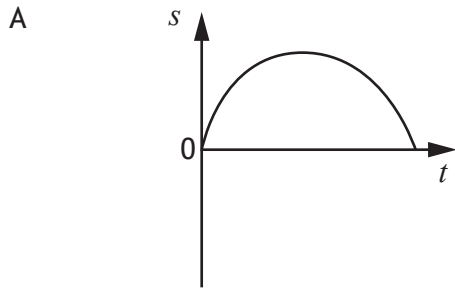

3. A box is suspended from a ceiling by a rope.
A horizontal force F is acting on the box.
The box is held stationary as shown.

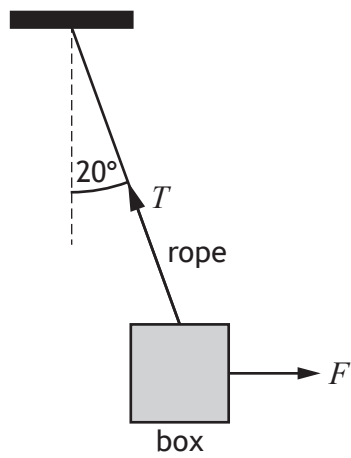

The weight of the box is 4.9 N.

The tension T in the rope is

- A 1.7 N
- B 4.6 N
- C 4.9 N
- D 5.2 N
- E 14 N.

[Turn over

4. A ball is thrown horizontally over the edge of a cliff.

A group of students draw three velocity-time ($v-t$) graphs to represent the motion of the ball, when air resistance is taken into account.

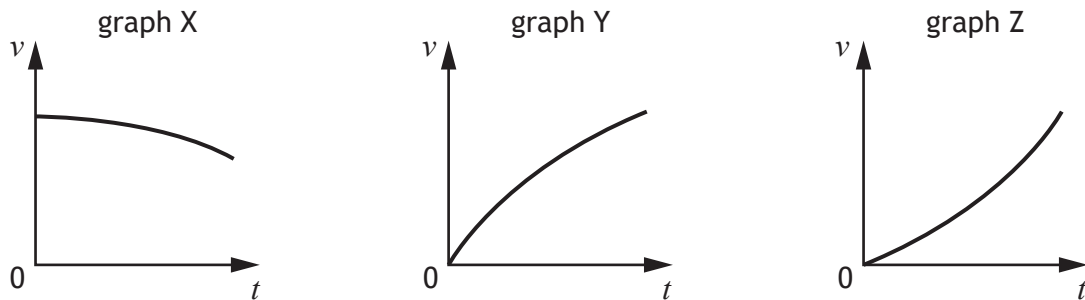

Which row in the table shows the graphs that represent the horizontal component of the velocity and the vertical component of the velocity?

	Horizontal component of the velocity	Vertical component of the velocity
A	graph X	graph Y
B	graph X	graph Z
C	graph Y	graph X
D	graph Y	graph Z
E	graph Z	graph X

5. In a hydroelectric power station water flows from a reservoir through turbines at a rate of 4.5×10^6 kg per minute.

The reservoir is 150 m above the turbines.

The total power delivered by the water in falling from the reservoir to the turbines is

- A 3.0×10^4 W
- B 7.5×10^4 W
- C 1.1×10^8 W
- D 6.6×10^9 W
- E 4.0×10^{12} W.

6. Two trolleys move along a level bench as shown.

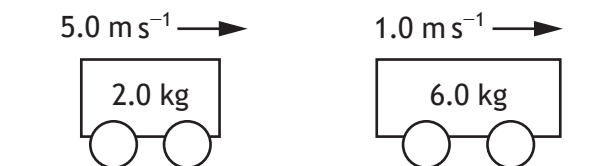

The trolleys collide and stick together. They continue to move along the bench.

The velocity of the trolleys immediately after the collision is

- A 0.50 m s⁻¹
B 1.3 m s⁻¹
C 2.0 m s⁻¹
D 2.7 m s⁻¹
E 8.0 m s⁻¹.
7. A spacecraft is travelling at a speed of $0.20c$ relative to the Earth.
The spacecraft emits a signal for 20.0 s as measured in the frame of reference of the spacecraft.
An observer on Earth measures the duration of the signal as
- A 19.2 s
B 19.6 s
C 20.0 s
D 20.4 s
E 20.8 s.
8. The Queensferry Crossing has a length of 2700 m as measured by a stationary observer on Earth.
A spaceship travels past Earth at a constant speed of 1.80×10^8 m s⁻¹ relative to Earth.
The length of the Queensferry Crossing as measured by an observer on the spaceship is
- A 1100 m
B 1700 m
C 2200 m
D 3400 m
E 4300 m.

[Turn over

9. The graph shows how the energy emitted per second per unit area varies with the wavelength of the radiation for four stars W, X, Y, and Z.

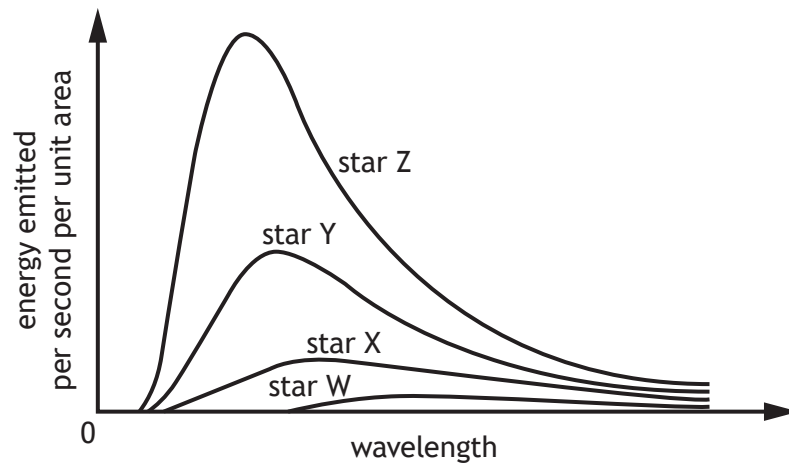

A student makes the following statements based on the information shown in the graph:

- I Star Z is hotter than star W.
- II The peak frequency of radiation emitted is greatest for star W.
- III Star Y emits more energy per second per unit area than star X.

Which of the statements is/are correct?

- A I only
 - B II only
 - C III only
 - D I and III only
 - E I, II and III
10. Which of the following particles is a fermion?
- A W-boson
 - B Z-boson
 - C Photon
 - D Gluon
 - E Muon

11. The following statement represents beta decay.

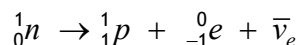

Beta decay provided the first evidence for the existence of the

- A quark
 - B neutrino
 - C electron
 - D proton
 - E neutron.
12. Uranium-239 (${}^{239}_{92}\text{U}$) undergoes decay by emitting a beta particle. The nucleus formed as a result of this decay also undergoes decay by emitting a beta particle to form nucleus X.

Nucleus X is

- A ${}^{231}_{88}\text{Ra}$
- B ${}^{235}_{90}\text{Th}$
- C ${}^{239}_{90}\text{Th}$
- D ${}^{239}_{93}\text{Np}$
- E ${}^{239}_{94}\text{Pu}$.

13. The following statement represents a nuclear reaction.

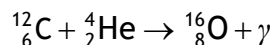

The total mass of the particles before the reaction is 26.572×10^{-27} kg.

The total mass of the particles after the reaction is 26.560×10^{-27} kg.

The energy released in this reaction is

- A 1.20×10^{-29} J
- B 3.60×10^{-21} J
- C 5.40×10^{-13} J
- D 1.08×10^{-12} J
- E 2.39×10^{-9} J.

[Turn over

14. A student carries out an experiment to investigate how irradiance of light varies with distance.

A small lamp is placed at a distance d from a light meter. The irradiance I at this distance is displayed on the light meter. This measurement is repeated for a range of different distances.

The student uses these results to plot the graph shown.

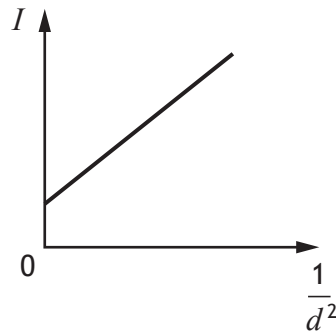

The graph indicates that there is a systematic uncertainty in the experiment.

Which of the following alterations would be most likely to reduce the systematic uncertainty in this experiment?

- A Repeating the experiment in a darkened room
 - B Repeating the readings at each distance and calculating averages
 - C Decreasing the brightness of the lamp
 - D Replacing the small lamp with a larger lamp
 - E Increasing the range of distances
15. A group of students make the following statements about coherent waves:
- I Coherent waves have a constant phase relationship.
 - II Coherent waves have the same frequency.
 - III Coherent waves have the same speed.

Which of the statements is/are correct?

- A I only
- B III only
- C I and II only
- D II and III only
- E I, II and III

16. Dark lines in an absorption spectrum occur because
- A photons move from higher to lower energy levels emitting electrons
 - B photons move from lower to higher energy levels by absorbing electrons
 - C electrons move from lower to higher energy levels emitting photons
 - D electrons move from higher to lower energy levels emitting photons
 - E electrons move from lower to higher energy levels by absorbing photons.

17. A ray of monochromatic light passes from air into diamond.

The frequency of the light in air is 5.09×10^{14} Hz.

The speed of this light in diamond is

- A $1.40 \times 10^2 \text{ m s}^{-1}$
- B $1.70 \times 10^6 \text{ m s}^{-1}$
- C $1.24 \times 10^8 \text{ m s}^{-1}$
- D $3.00 \times 10^8 \text{ m s}^{-1}$
- E $7.26 \times 10^8 \text{ m s}^{-1}$.

18. A circuit is set up as shown.

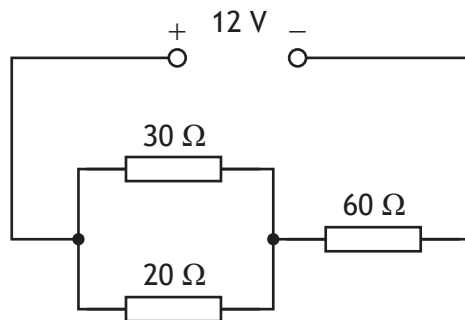

The power supply has negligible internal resistance.

The potential difference across the 60Ω resistor is

- A 1.0 V
- B 2.0 V
- C 5.5 V
- D 6.5 V
- E 10 V.

[Turn over

19. A resistor of resistance $2.2 \text{ k}\Omega$ is rated at 0.25 W .
 The potential difference across the resistor when operating at its rated power is
- A 0.11 V
 - B 23 V
 - C 94 V
 - D 550 V
 - E 8800 V .

20. A circuit is set up as shown.

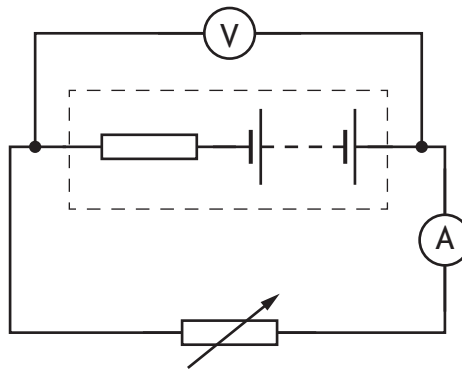

The resistance of the variable resistor is changed and the corresponding readings on the ammeter and voltmeter are used to produce the graph shown.

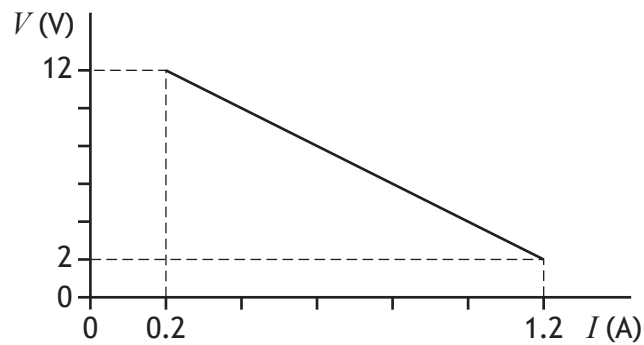

A student makes the following statements based on this information:

- I The EMF of the battery is 12 V .
- II The internal resistance of the battery is 10Ω .
- III The short circuit current is 1.2 A .

Which of these statements is/are correct?

- A I only
- B II only
- C III only
- D I and II only
- E I, II and III

21. A capacitor is initially uncharged.

The capacitor is now charged for 20 s using a supply that provides a constant current of 0.10 mA.

The potential difference across the capacitor is now 12 V.

The energy stored in the capacitor is

- A 0.06 mJ
- B 12.0 mJ
- C 14.4 mJ
- D 24.0 mJ
- E 28.8 mJ.

[Turn over

22. A circuit is set up as shown.

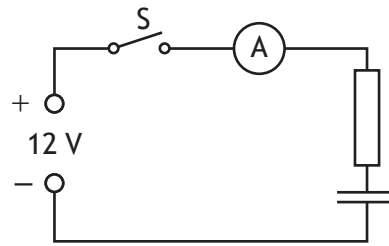

The capacitor is initially uncharged.

Switch S is now closed and the capacitor charges.

The graph shows how the charging current I in the circuit varies with time t .

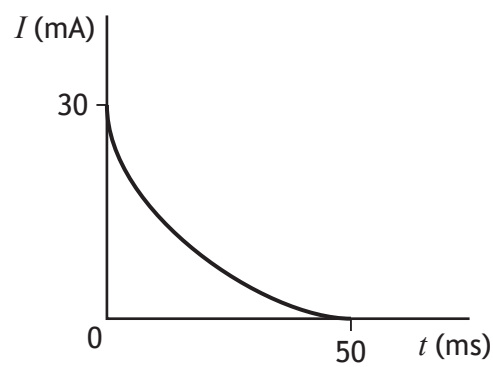

The capacitor is now replaced with an uncharged capacitor of greater capacitance.

The same charging process is repeated with this capacitor.

22. (continued)

Which graph shows how the current I varies with time t as this capacitor charges?

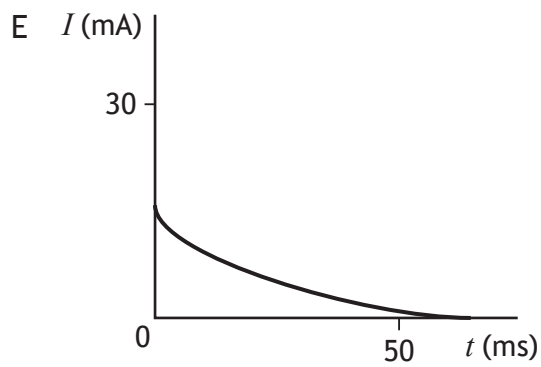
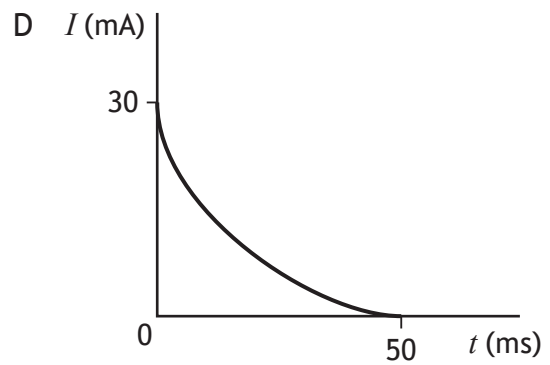
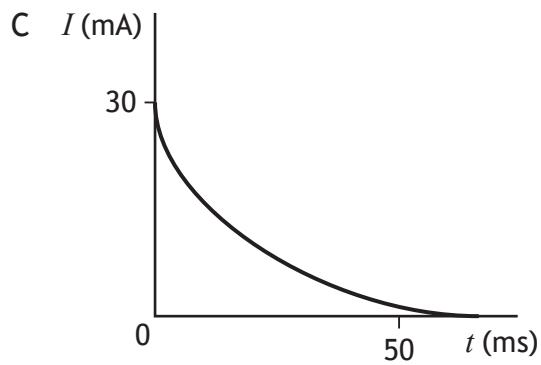
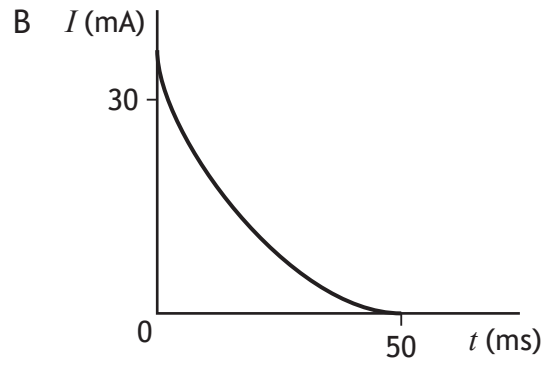
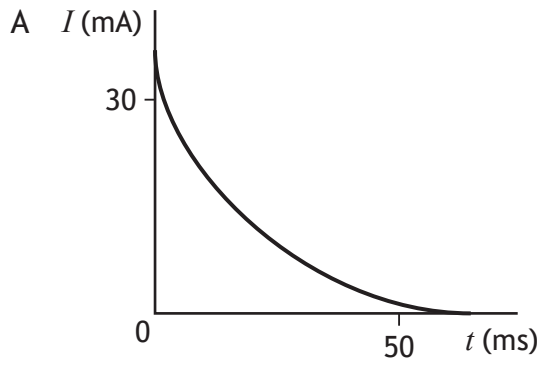

[Turn over

23. Solids can be categorised as conductors, insulators, or semiconductors.

The diagrams show the valence band and conduction bands of three solids X, Y, and Z.

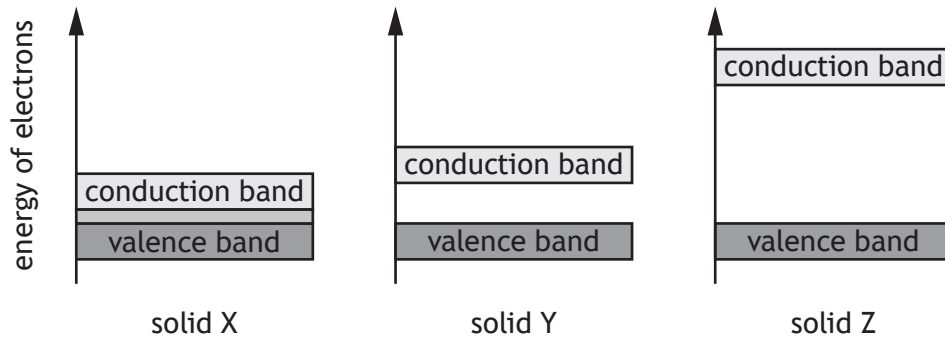

Which row in the table shows the letters that represent a conductor, an insulator, and a semiconductor?

	Conductor	Insulator	Semiconductor
A	X	Y	Z
B	Z	X	Y
C	Y	Z	X
D	X	Z	Y
E	Z	Y	X

24. An increase in the temperature of a semiconductor
- A increases its conductivity by allowing more electrons to reach the conduction band
 - B increases its conductivity by increasing the band gap between the valence band and the conduction band
 - C decreases its conductivity by allowing more electrons to reach the conduction band
 - D decreases its conductivity by allowing fewer electrons to reach the conduction band
 - E has no effect on its conductivity.
25. A student connects four identical red light emitting diodes (LEDs) to a 2 V rms AC supply as shown.

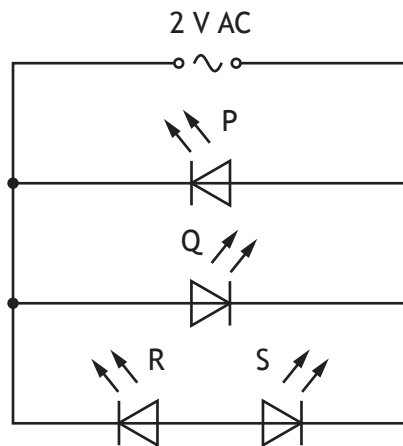

Which of the LEDs P, Q, R, and S will emit light?

- A P only
- B Q only
- C P and Q only
- D P and R only
- E Q and S only

[END OF QUESTION PAPER]

SPACE FOR ROUGH WORK

SPACE FOR ROUGH WORK

[BLANK PAGE]

DO NOT WRITE ON THIS PAGE