

FOR OFFICIAL USE



National  
Qualifications  
2024

Mark

**X862/75/02**

**Practical Woodworking**

WEDNESDAY, 22 MAY

1:30 PM – 2:30 PM



\* X 8 6 2 7 5 0 2 \*

Fill in these boxes and read what is printed below.

Full name of centre

Town

Forename(s)

Surname

Number of seat

Date of birth

Day

Month

Year

Scottish candidate number

**Total marks — 60**

Attempt ALL questions.

**You may use a calculator.**

Write your answers clearly in the spaces provided in this booklet. Additional space for answers is provided at the end of this booklet. If you use this space you must clearly identify the question number you are attempting.

Use **blue** or **black** ink.

Before leaving the examination room you must give this booklet to the Invigilator; if you do not, you may lose all the marks for this paper.



\* X 8 6 2 7 5 0 2 0 1 \*

Total marks — 60  
 Attempt ALL questions

1. A company manufactures traditional toys such as the wooden puzzle shown below.

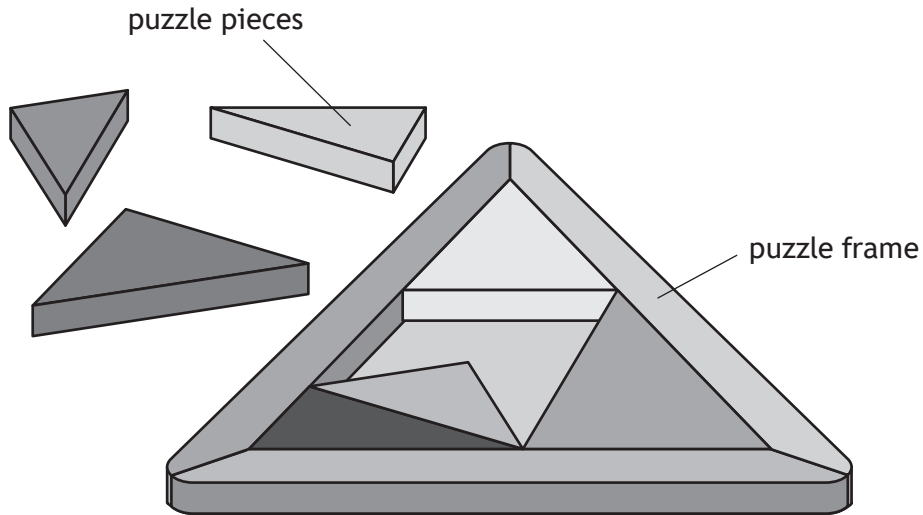

(a) The hardwood oak is used for the puzzle frame.

Tick two identifying features of hardwoods from the table below.

2

They come from coniferous trees	<input type="checkbox"/>
They are fast growing	<input type="checkbox"/>
They come from broadleaved trees	<input type="checkbox"/>
They are known as 'evergreens'	<input type="checkbox"/>
They are described as 'deciduous'	<input type="checkbox"/>

(b) State two material properties of oak which make it suitable for a toy.

2

1 \_\_\_\_\_

2 \_\_\_\_\_



1. (continued)

A working drawing for the puzzle frame is shown.

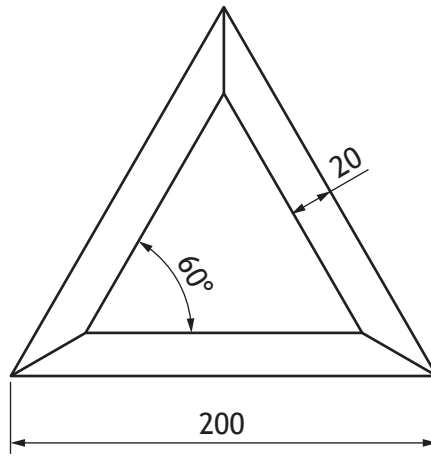

The puzzle frame was marked out on one piece of timber as shown below.

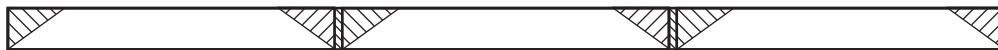

- (c) Calculate the minimum length of timber required to make the frame if 5 mm of waste is allowed between each side.

1

---

- (d) State a measuring tool, other than a steel rule, that can be used to mark out the puzzle frame on the timber.

1

---

- (e) Identify how the frame can be marked out to reduce waste on the diagram below. You may use sketches to support your answer.

1

---

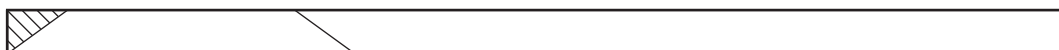

[Turn over

1. (continued)

- (f) Name an adjustable marking tool that can be used to mark out the mitre angle on the frame.

1

---

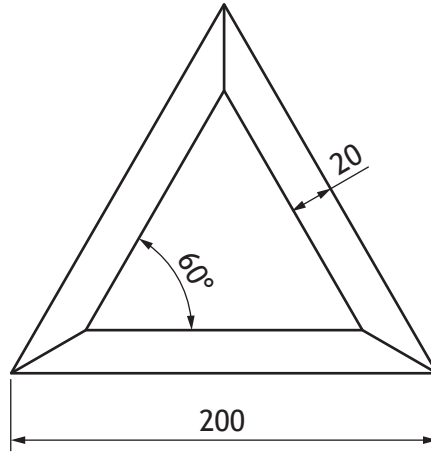

- (g) State the angle this tool must be set to using the working drawing shown above.

1

---

1. (continued)

The cramping device shown below is used to assemble the puzzle frame.

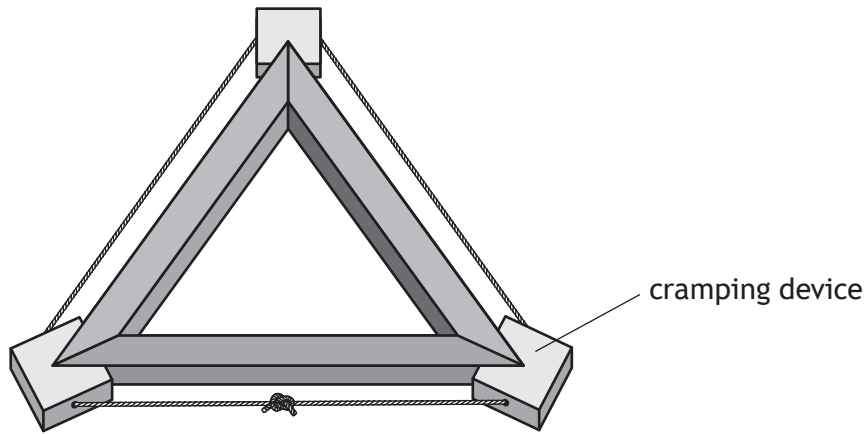

(h) State the name of the cramping device.

1

\_\_\_\_\_

[Turn over

1. (continued)

Mitre joints are used for the corners of the frame.

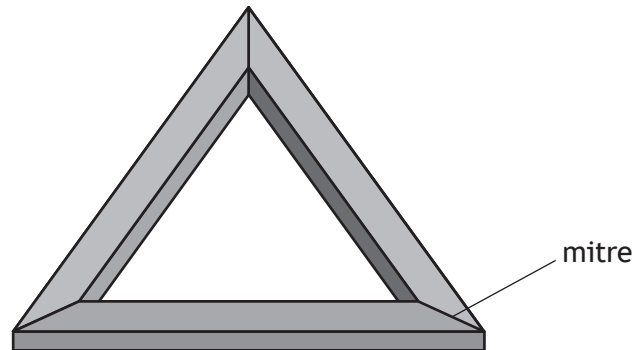

- (i) Describe two difficulties that may be encountered when assembling a frame with mitre joints.

2

1 \_\_\_\_\_

2 \_\_\_\_\_

- (j) Hardboard is used for the base of the puzzle frame and is attached using the fixing shown below.

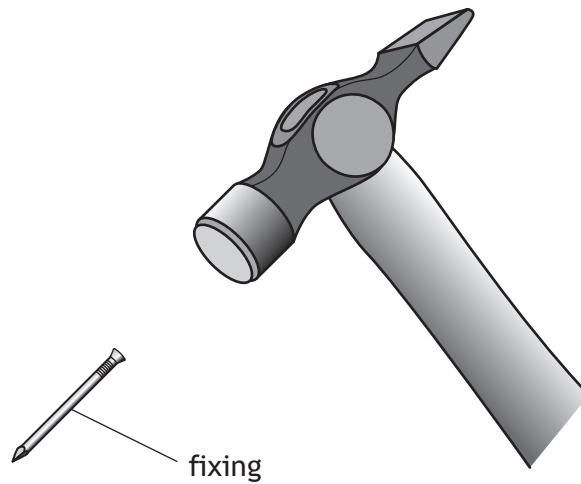

State the name of this fixing.

1

\_\_\_\_\_

1. (continued)

- (k) The puzzle pieces are manufactured from waste material found in the workshop.

Describe two **environmental** benefits of using waste material.

2

---

---

---

---

[Turn over



2. A wooden tray is shown below.

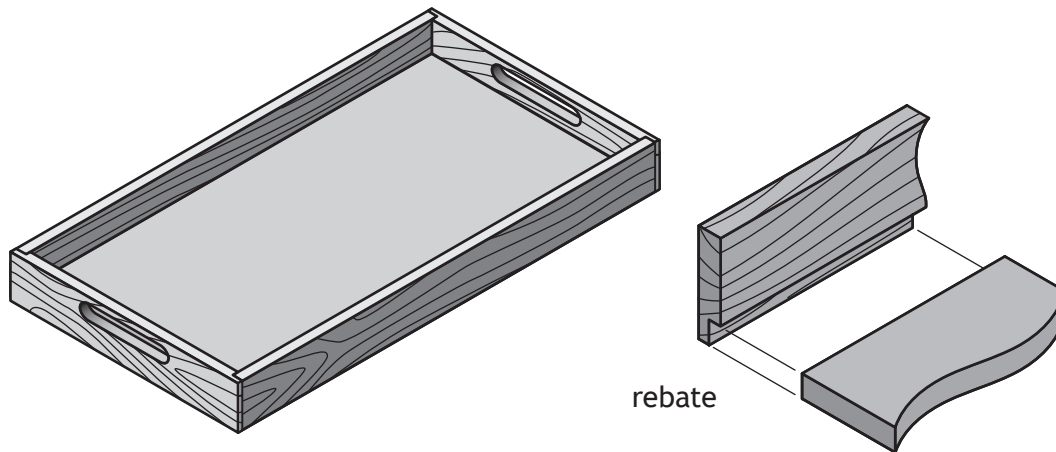

(a) The bottom of the timber frame was rebated **before** cutting into sections and assembling.

Explain why this process is completed first.

1

---



---

(b) The rebate plane shown below was used to cut the rebate.

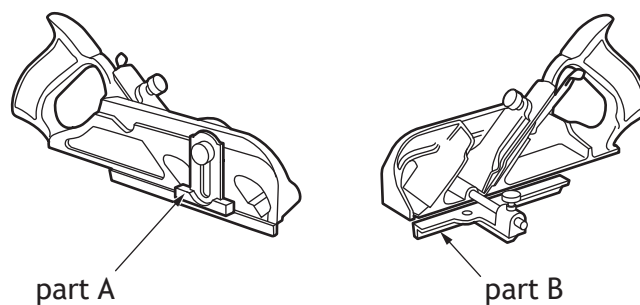

Describe the **function** of parts A and B.

2

Part A \_\_\_\_\_

Part B \_\_\_\_\_





2. (continued)

The process shown is used to prepare the surfaces of the timber prior to applying a finish.



(c) Name the process shown above. 1

\_\_\_\_\_

(d) Surface preparation can also be done using power tools.  
State the name of a suitable power tool. 1

\_\_\_\_\_

(e) The wooden tray is finished with stain.  
Explain two advantages of using stain as a finish instead of varnish. 2

Advantage 1 \_\_\_\_\_

\_\_\_\_\_

Advantage 2 \_\_\_\_\_

\_\_\_\_\_

[Turn over



2. (continued)

(f) Describe how stain is applied to ensure a high-quality surface finish.

2

---

---

---

(g) The stain is solvent based.

State two safety precautions that would be undertaken when using a solvent based finish.

2

1 \_\_\_\_\_

2 \_\_\_\_\_



[Turn over for next question

DO NOT WRITE ON THIS PAGE



\* X 8 6 2 7 5 0 2 1 1 \*

3. A bench with storage compartments is shown below.

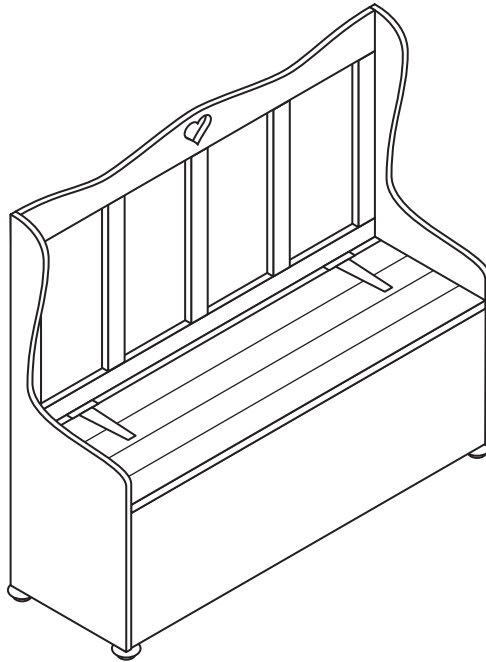

(a) The joints, shown below, join the top rail to the stiles.

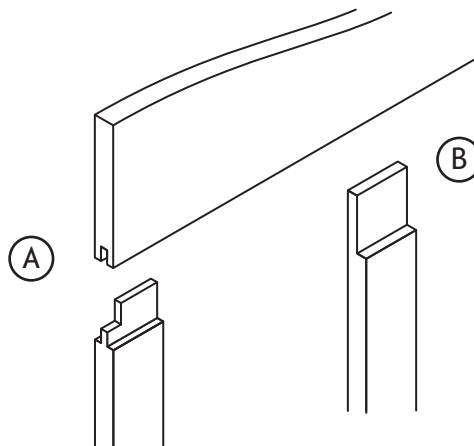

(i) State the name of joint A.

1

---

(ii) State the name of joint B.

1

---



3. (a) (continued)

(iii) Identify the ratio **joint A** is usually cut to by ticking (✓) a box below.

1

1:4 thickness       1:3 thickness       1:2 thickness

(iv) Explain why joint A was used for the corner of the frame.

1

---

---

[Turn over



3. (continued)

A heart has been cut in the top rail.

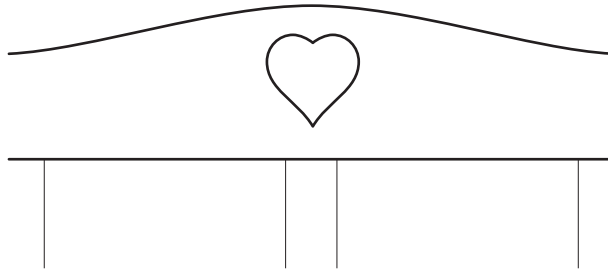

The tools shown were used in its manufacture.

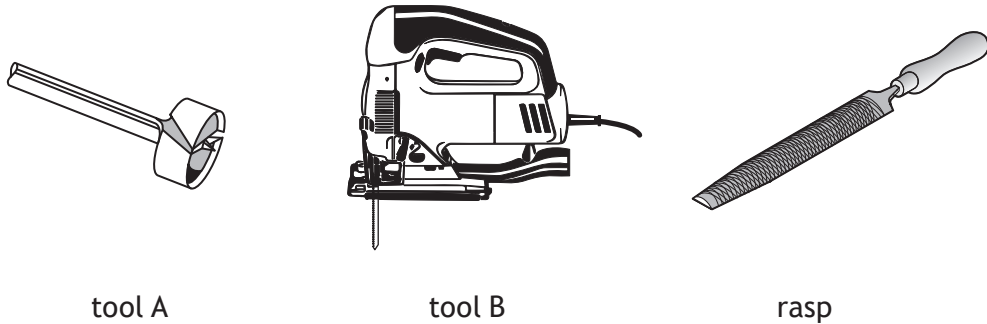

(b) State the name of the following tools.

2

Tool A \_\_\_\_\_

Tool B \_\_\_\_\_

3. (continued)

- (c) Describe how the heart could be manufactured using the tools shown opposite. 3  
You may use sketches to support your answer.



3. (continued)

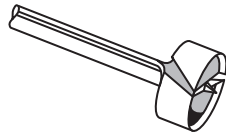

tool A

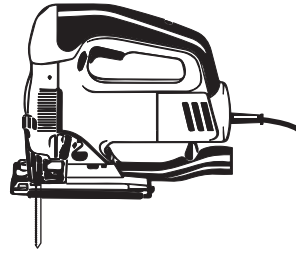

tool B

- (d) When using **tool A**, shown above, the manufacturer found there was splintering on the underside of the wood.

Describe what can be done to minimise the chance of this happening.

1

---



---

- (e) State two safety checks carried out to **tool B**, shown above, before use.

2

Check 1 \_\_\_\_\_

Check 2 \_\_\_\_\_

The top rail has a curved edge.

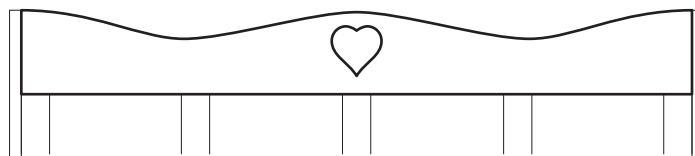

- (f) State the name of two **hand tools**, other than a rasp, that could be used to form the curved edge if tool B was unavailable.

2

1 \_\_\_\_\_

2 \_\_\_\_\_



[Turn over for next question

DO NOT WRITE ON THIS PAGE



\* X 8 6 2 7 5 0 2 1 7 \*

3. (continued)

There are storage compartments under the seat.

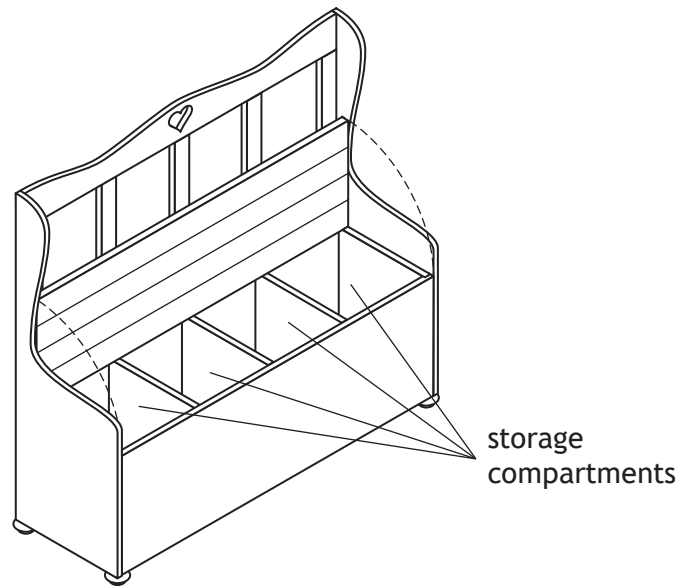

The storage compartments were constructed using stopped housing and rebate joints as shown in the diagram below.

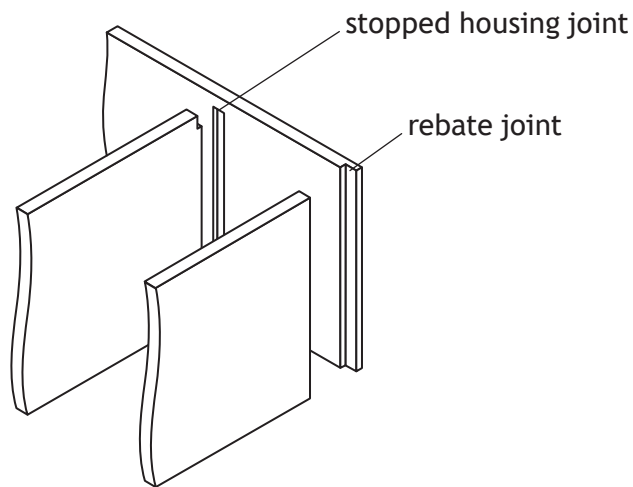

3. (continued)

The tool shown below can be used to mark out stopped housing and rebate joints.

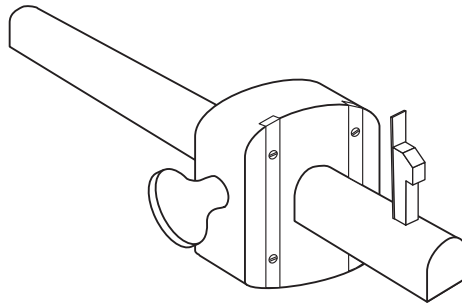

(g) State the name of this tool.

1

\_\_\_\_\_

When manufacturing the rebate joint the wood split as shown below.



(h) Explain why this has happened.

1

\_\_\_\_\_  
\_\_\_\_\_

[Turn over

3. (continued)

After removing waste material, the tool shown below was used to finish the rebate joint.

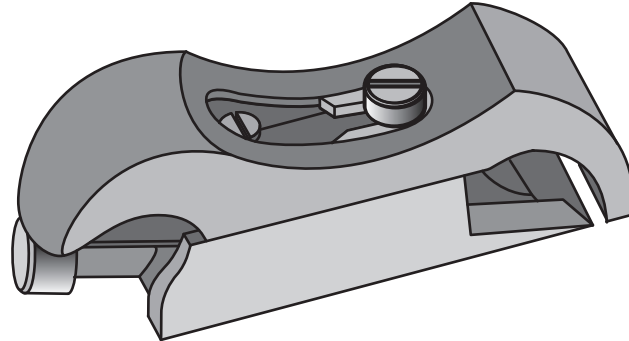

- (i) State the name of this tool.

1

---

3. (continued)

A stopped housing joint is shown below.

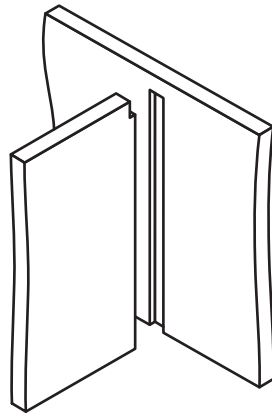

- (j) Describe two stages involved in cutting a stopped housing joint.  
You may use sketches to support your answer.

2

Blank area for the student to provide a written answer and sketches for the question.

3. (continued)

(k) After cutting the joints the tool shown below was used to assemble the storage compartments.

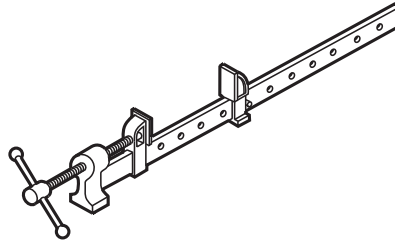

(i) State the name of this tool.

1

\_\_\_\_\_

(ii) State two checks that would be undertaken immediately after gluing and cramping the storage compartments.

2

Check 1 \_\_\_\_\_

Check 2 \_\_\_\_\_



3. (continued)

Solid wood and manufactured boards were considered for the seat.

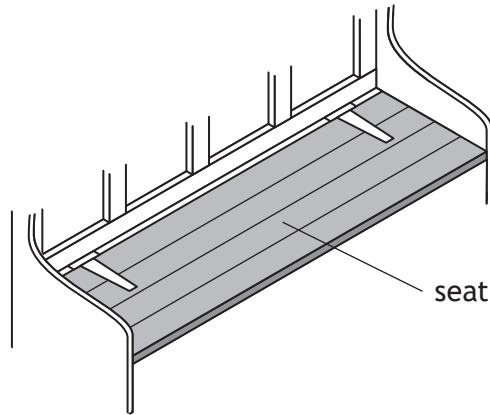

One option for the seat was to use the manufactured board shown below.

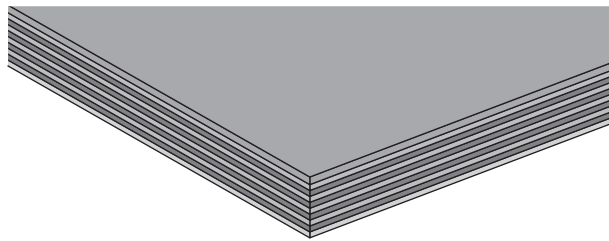

- (l) State the name of this type of manufactured board. 1

\_\_\_\_\_

Veneered chipboard was another manufactured board considered for use.

- (m) (i) State one **advantage** of using chipboard instead of pine with regards to its **environmental** impact. 1

\_\_\_\_\_

- (ii) State one **disadvantage** of using chipboard for the seat instead of pine. 1

\_\_\_\_\_

[Turn over

3. (continued)

(n) Describe why it is important to use wood obtained from sustainable sources.

1

---

---

---





4. A pepper grinder and associated working drawing are shown below.

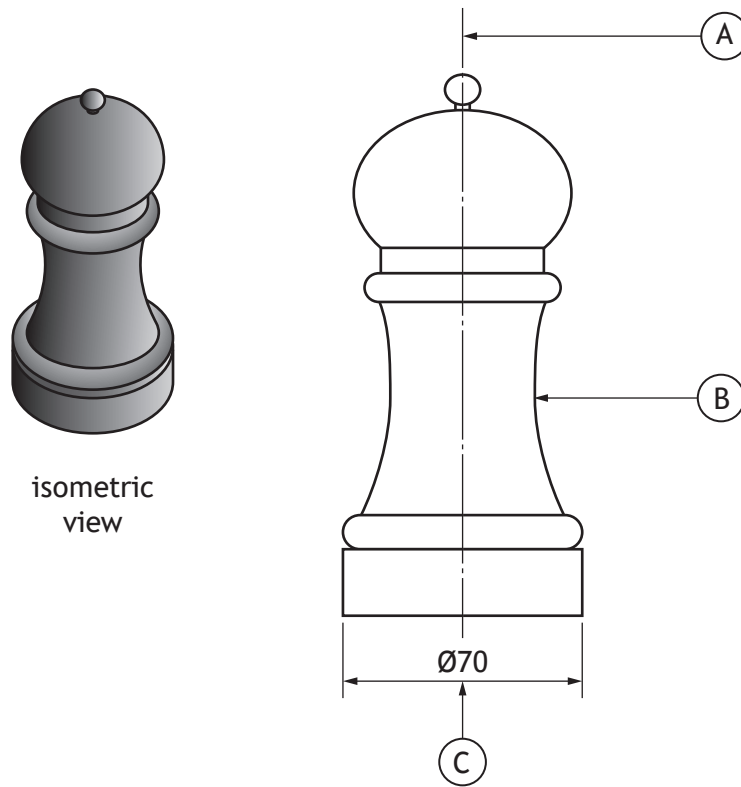

- (a) (i) State the line type shown at A. 1
- \_\_\_\_\_
- (ii) State what the symbol  $\emptyset$  means at C. 1
- \_\_\_\_\_
- (b) State the name of a tool which can be used to turn the feature at B on the woodturning lathe. 1
- \_\_\_\_\_
- (c) Name the tool that is used to check the dimension at C after turning. 1
- \_\_\_\_\_

[Turn over



4. (continued)

The woodturning lathe was set up as shown below.



(d) State four safety issues with the machine shown in this image.

4

- 1 \_\_\_\_\_
- 2 \_\_\_\_\_
- 3 \_\_\_\_\_
- 4 \_\_\_\_\_

[END OF QUESTION PAPER]



MARKS DO NOT  
WRITE IN  
THIS  
MARGIN

ADDITIONAL SPACE FOR ANSWERS



**MARKS** DO NOT  
WRITE IN  
THIS  
MARGIN

ADDITIONAL SPACE FOR ANSWERS

