

FOR OFFICIAL USE



National  
Qualifications  
2024

Mark

**X860/75/02**

**Practical Electronics**

MONDAY, 29 APRIL

1:00 PM – 2:00 PM



\* X 8 6 0 7 5 0 2 \*

Fill in these boxes and read what is printed below.

Full name of centre

Town

Forename(s)

Surname

Number of seat

Date of birth

Day

Month

Year

Scottish candidate number

**Total marks — 60**

Attempt ALL questions.

**You may use a calculator.**

Write your answers clearly in the spaces provided in this booklet. Additional space for answers is provided at the end of this booklet. If you use this space you must clearly identify the question number you are attempting.

Use **blue** or **black** ink.

Before leaving the examination room you must give this booklet to the Invigilator; if you do not, you may lose all the marks for this paper.



\* X 8 6 0 7 5 0 2 0 1 \*

**Total marks — 60**  
**Attempt ALL questions**

1. The table below gives information about some circuit components.  
 Some of the boxes have been left blank.

(a) Complete the table for the missing entries.

**3**

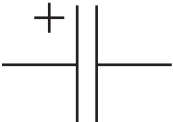
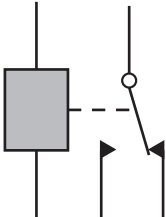
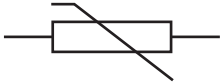
Component name	Symbol	Function
Electrolytic capacitor		stores charge
		electromagnetic switch
Diode		allows current to flow in one direction only
Thermistor		

1. (continued)

(b) A technician selects a resistor with the colour coding as shown below.

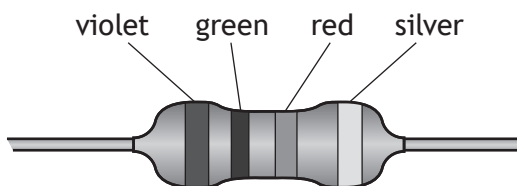

Use the information in the data sheet to answer the questions below.

(i) Determine the resistance of this resistor.

1

(ii) State the percentage tolerance of this resistor.

1

(iii) Determine the maximum and minimum resistance of this resistor in ohms.

2



2. State two safety precautions that must be taken when using a soldering iron.

2

3. A circuit diagram is shown below.

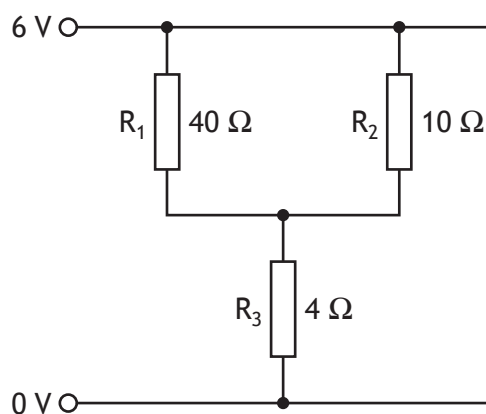

(a) (i) Calculate the effective resistance of  $R_1$  and  $R_2$  in parallel.  
*Space for working and answer*

3

(ii) Calculate the total resistance of this circuit.  
*Space for working and answer*

1



3. (continued)

(b) Calculate the current in resistor  $R_3$ .

*Space for working and answer*

3

(c) Calculate the power dissipated in resistor  $R_3$ .

*Space for working and answer*

3

[Turn over



4. There are many different types of logic gate used in electronics.

(a) Complete the truth table for an AND gate.

1

A	B	Output
0	0	
0	1	
1	0	
1	1	

(An additional truth table, if required, can be found on *page 16*.)

(b) Name the logic gate shown below.

1

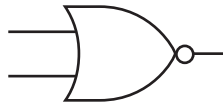

4. (continued)

(c) Complete the truth table for the logic circuit shown below.

3

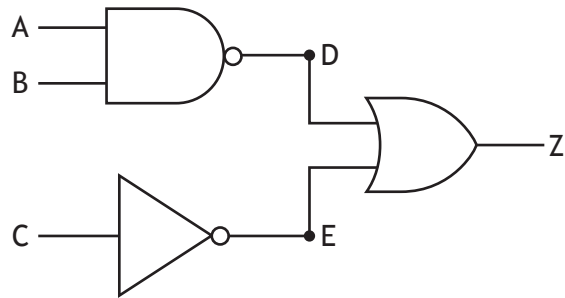

A	B	C	D	E	Z
0	0	0			
0	0	1			
0	1	0			
0	1	1			
1	0	0			
1	0	1			
1	1	0			
1	1	1			

(An additional truth table, if required, can be found on page 16.)

[Turn over

5. Simulation is used in circuit design.

MARKS DO NOT WRITE IN THIS MARGIN

(a) State **two** reasons for simulating a circuit before it is constructed.

2

(b) A student simulated the flashing LED circuit shown below.

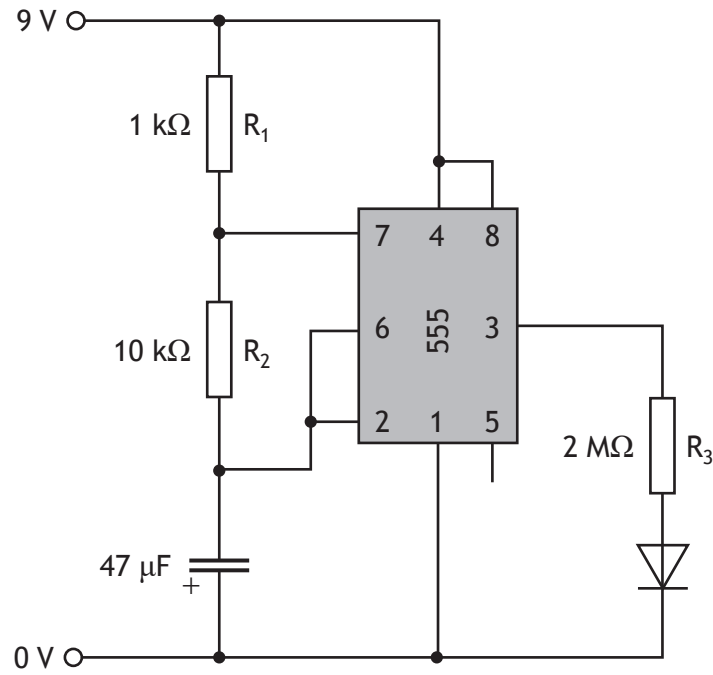

Identify **three** errors in the student's circuit.

3

Error 1:

Error 2:

Error 3:





6. A technician constructed a circuit from the schematic diagram shown below.

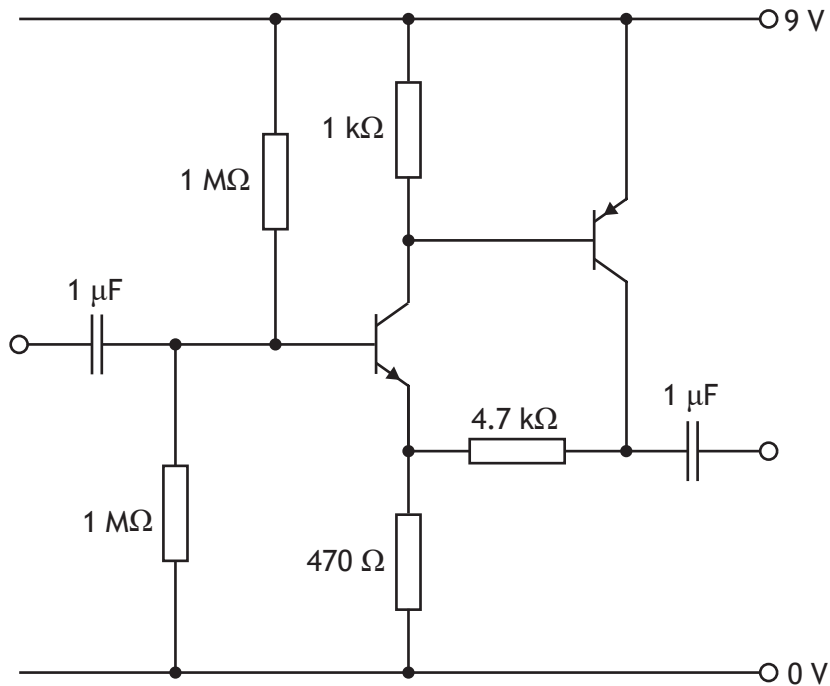

Complete the following table by giving **three** pre-power up checks for this circuit.

3

Pre-power up checklist
Correct power supply voltage

[Turn over



7. A student wants to check that the current flowing through a component is 1.2 mA DC.

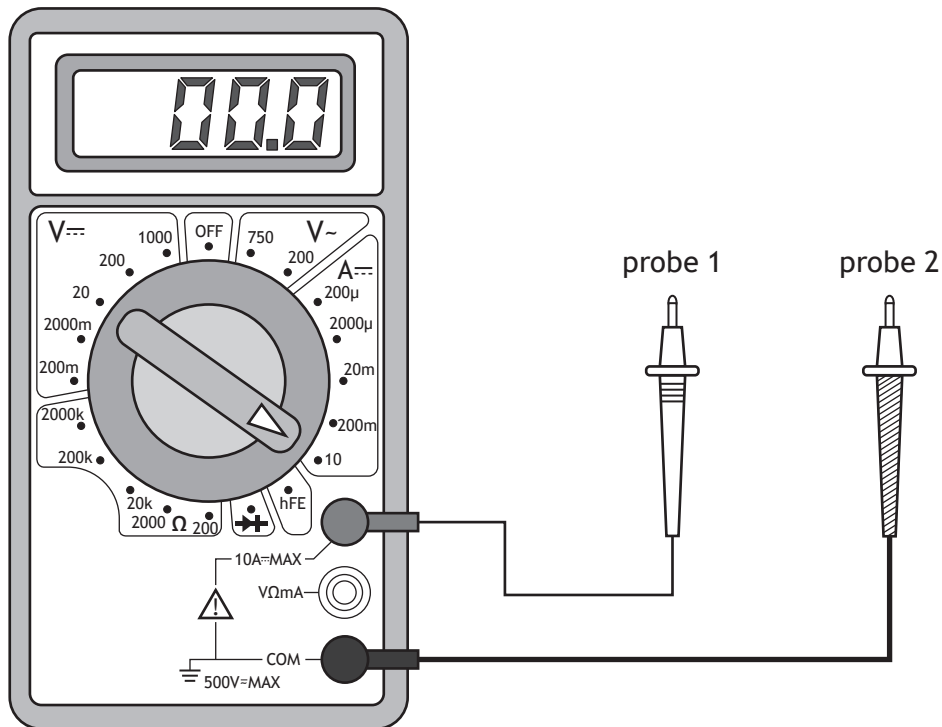

- (a) Identify **two** changes that must be made to the multimeter to get the most accurate measurement.

2

Change 1:

Change 2:

- (b) Draw the symbol for direct current that is shown on the meter.

1

- (c) State the most appropriate scale that should be used to check the resistance of a 15 000 Ω resistor.

1



8. The output from a signal generator is connected to the input terminals of an oscilloscope.

The trace is shown on the screen.

The Y-gain and timebase settings are also shown below.

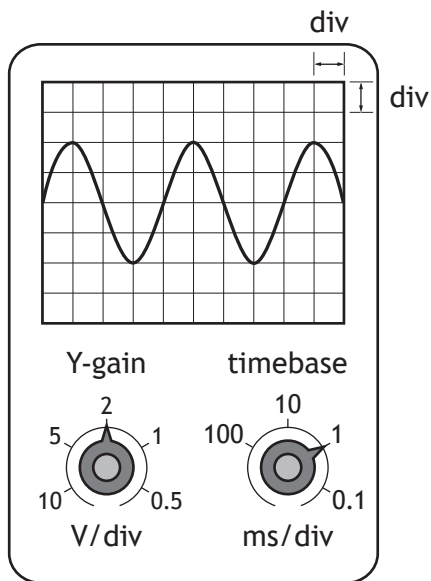

- (a) State whether this signal is analogue or digital.

1

- (b) Determine the peak voltage of this signal.

1

- (c) Calculate the frequency of this signal.

3

*Space for working and answer*



9. A child's LED night light is controlled using a LM741 comparator circuit as shown below.

MARKS DO NOT WRITE IN THIS MARGIN

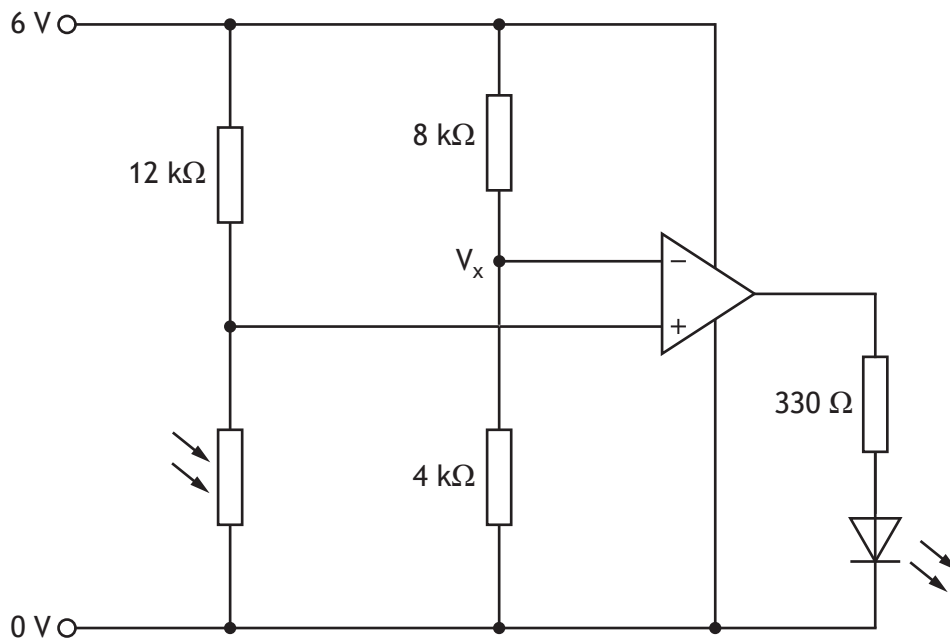

- (a) Calculate the reference voltage  $V_x$ .  
Space for working and answer

3

- (b) State the resistance of the light dependent resistor when the voltage across it is equal to the reference voltage  $V_x$ .

1

- (c) Describe how this circuit works.

3



10. A security system for an art gallery is required to protect an expensive vase. The system must include a sensor that can detect if the vase has been lifted. When the vase is lifted, this will turn on an alarm and a motor which closes the shutter on the gallery door. There is also a master switch to turn the whole system on and off. Selecting from the elements given below, draw a **block diagram** of an electronic solution for this system. On your diagram, clearly indicate the input, process and output sections of your solution.

6

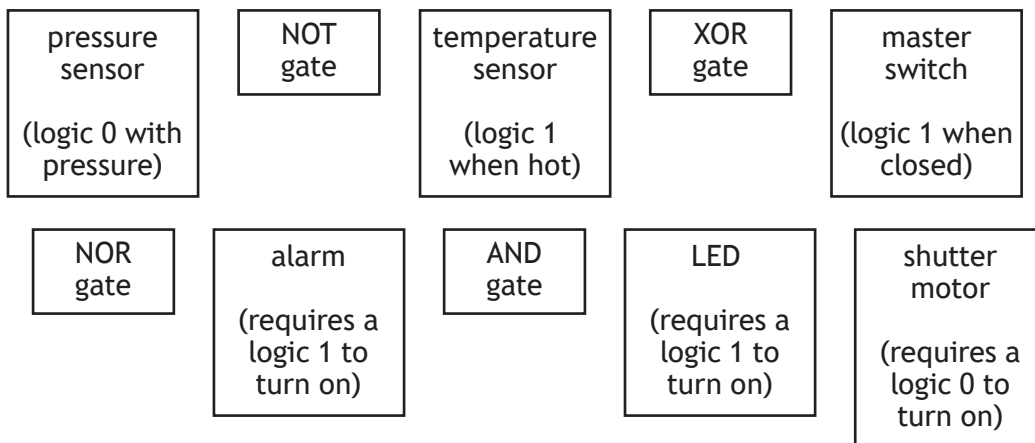

11. The stripboard plan below shows a component (top) view of a circuit with the following layout.

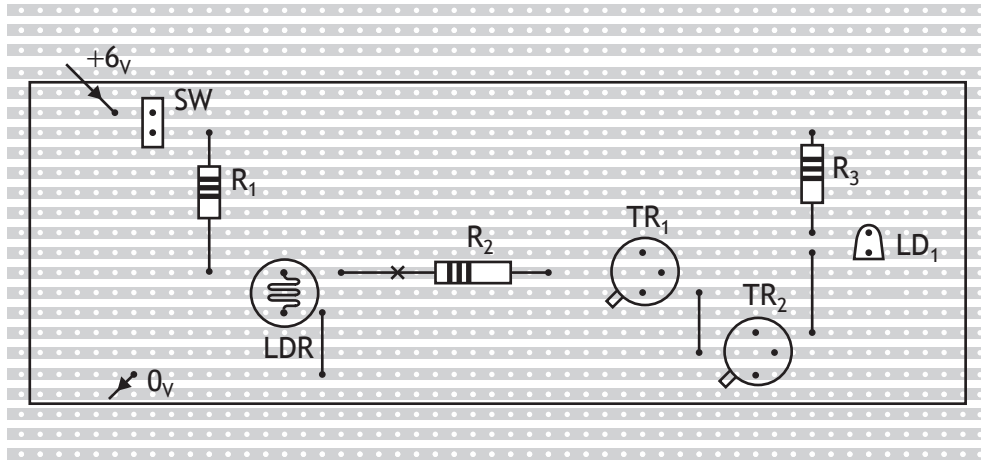

**Component data**

- TR<sub>1</sub> and TR<sub>2</sub> — BFY51 npn transistors
- LD<sub>1</sub> — 5 mm standard led (red)
- LDR — ORP12 light dependent resistor
- R<sub>1</sub> — carbon film 10 K 0.25 w
- R<sub>2</sub> — carbon film 6K8 0.25 w
- R<sub>3</sub> — carbon film 270 R 0.25 w
- SW — SPST switch (on/off switch)

**TR<sub>1</sub> and TR<sub>2</sub> pin connections**

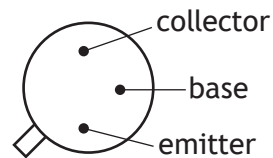

Draw a circuit diagram for this circuit.  
Each component must be labelled.

6

11. (continued)

[END OF QUESTION PAPER]



**ADDITIONAL SPACE FOR ANSWERS**

Additional truth table for question 4(a)

A	B	Output
0	0	
0	1	
1	0	
1	1	

Additional truth table for question 4(c)

A	B	C	D	E	Z
0	0	0			
0	0	1			
0	1	0			
0	1	1			
1	0	0			
1	0	1			
1	1	0			
1	1	1			



MARKS DO NOT  
WRITE IN  
THIS  
MARGIN

ADDITIONAL SPACE FOR ANSWERS



MARKS DO NOT  
WRITE IN  
THIS  
MARGIN

ADDITIONAL SPACE FOR ANSWERS



[BLANK PAGE]

DO NOT WRITE ON THIS PAGE



\* X 8 6 0 7 5 0 2 1 9 \*

[BLANK PAGE]

DO NOT WRITE ON THIS PAGE

