

FOR OFFICIAL USE



National  
Qualifications  
2019

Mark

**X861/75/01**

**Practical Metalworking**

MONDAY, 29 APRIL

2:30 PM – 3:30 PM



\* X 8 6 1 7 5 0 1 \*

Fill in these boxes and read what is printed below.

Full name of centre

Town

Forename(s)

Surname

Number of seat

Date of birth

Day

Month

Year

Scottish candidate number

**Total marks — 60**

Attempt ALL questions.

Write your answers clearly in the spaces provided in this booklet. Additional space for answers is provided at the end of this booklet. If you use this space you must clearly identify the question number you are attempting.

Use **blue** or **black** ink.

Before leaving the examination room you must give this booklet to the Invigilator; if you do not, you may lose all the marks for this paper.



\* X 8 6 1 7 5 0 1 0 1 \*

Total marks — 60  
Attempt ALL questions

1. A brass door plate for a sports changing room is shown below.

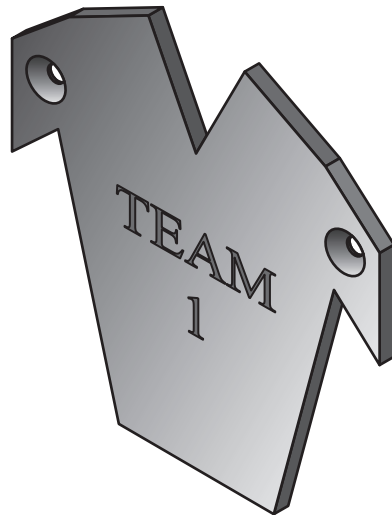

Brass is an alloy.

- (a) State what the term 'alloy' means.

1

---

- (b) State one property of brass.

1

---



## 1. (continued)

The image below shows an attempt at marking out multiple door plates on a sheet of brass.

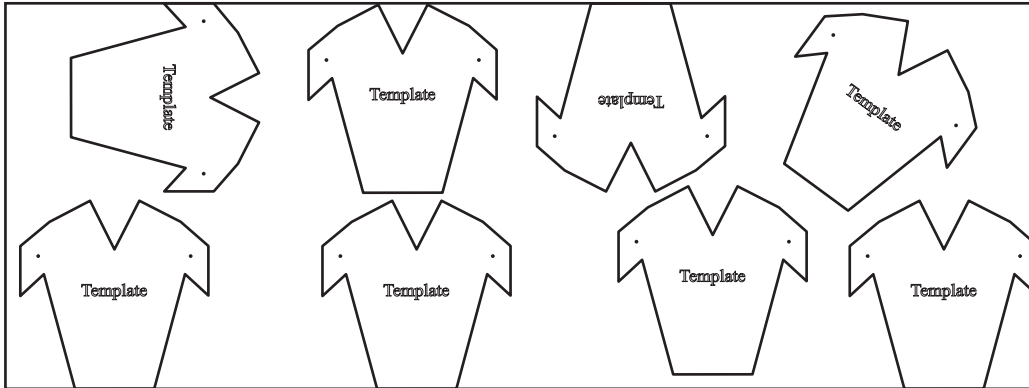

- (c) Explain why the image above demonstrates poor practice in marking out. 1  
You may use sketches to support your answer.



1. (continued)

Fixing screws are to sit flush with the face of the door plate as shown.

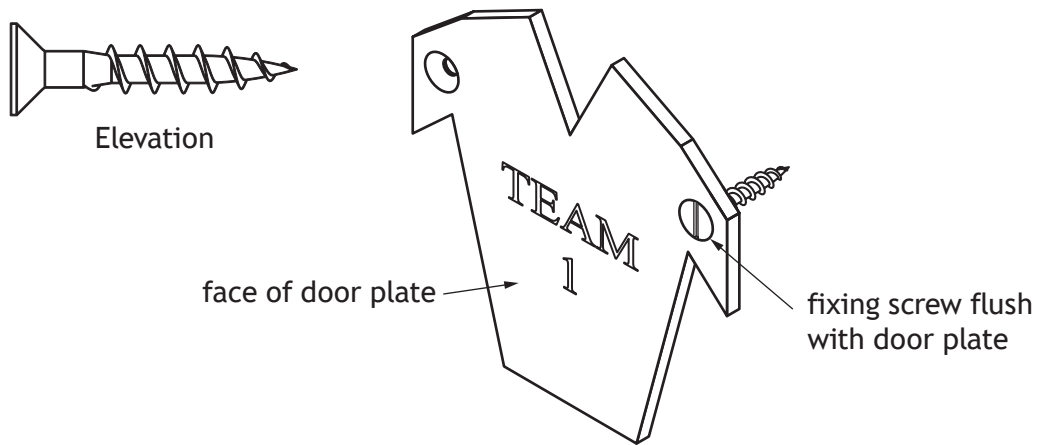

- (d) Describe how to use a pedestal/pillar drill to create the holes for the fixing screws.

3

You may use sketches to support your answer.

[Turn over for next question

DO NOT WRITE ON THIS PAGE



\* X 8 6 1 7 5 0 1 0 5 \*

2. A metal skipping rope handle made of two separate parts is shown below.

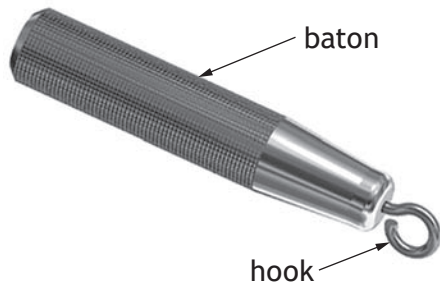

The working drawing for manufacturing the baton is shown below.

**Baton**

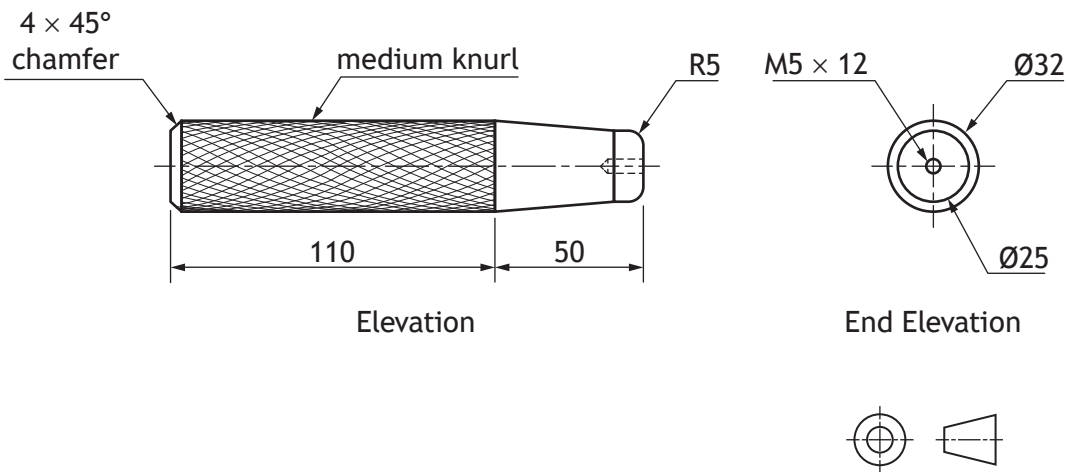

From the information given in the working drawing

(a) (i) explain what is meant by the term 'M5 × 12' 2

---



---



---

(ii) state the outside diameter of the baton. 1

\_\_\_\_\_ mm



2. (continued)

The elevation of the baton is shown below.

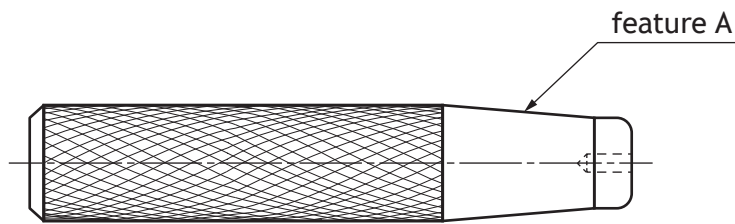

Elevation

- (b) State the name of the turning process used to create feature A, shown above.

1

\_\_\_\_\_

- (c) Describe two personal health and safety procedures which must be followed when carrying out a turning process.

2

1 \_\_\_\_\_

\_\_\_\_\_

2 \_\_\_\_\_

\_\_\_\_\_

[Turn over



2. (continued)

Two pupils have set up the centre lathe for knurling as shown below.

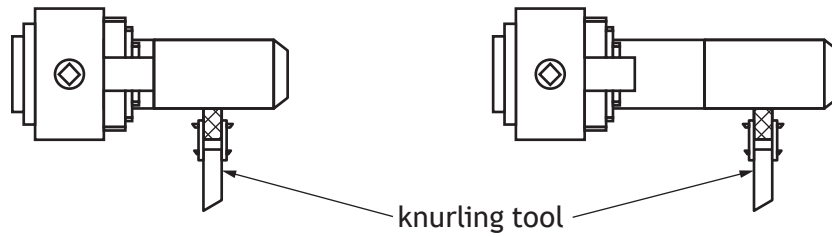

pupil A

pupil B

- (d) (i) Explain why pupil A is more likely to have a better knurled finish on their workpiece. 1

---



---

- (ii) Name the part of the centre lathe that holds the knurling tool. 1

---

- (e) State **two** properties of aluminium that make it a suitable material for the baton. 2

1 

---

---

2 

---

---



2. (continued)

Enlarged views of the blind hole on the baton are shown below.

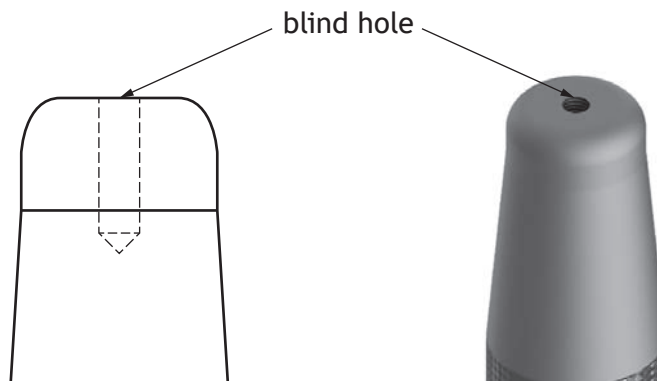

- (f) Explain why a centre lathe, rather than a pedestal/pillar drill, was used to drill the blind hole.

1

---



---

- (g) Explain why a 'plug tap' is used when creating an internal thread on a blind hole.

1

---



---

[Turn over



## 2. (continued)

An enlarged view of the chamfer on the baton is shown below.

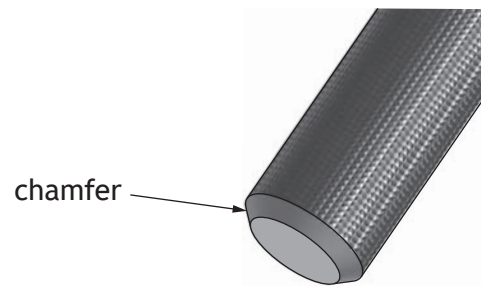

- (h) Describe how the chamfering process is carried out on the centre lathe.  
You may use sketches to support your answer.

2



## 2. (continued)

A lathe tool used in the manufacture of the baton is shown below.

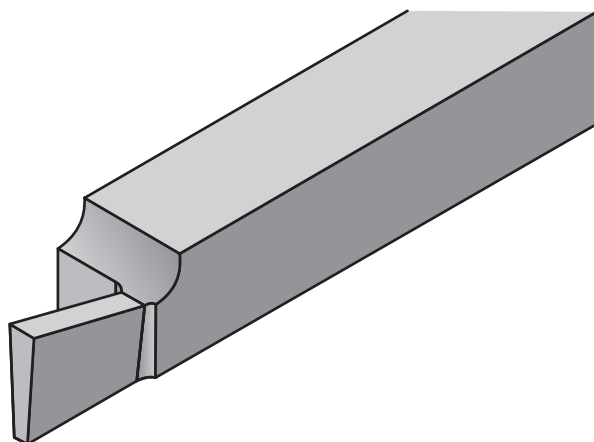

- (i) Explain the purpose of this tool.

1

---

---

[Turn over



\* X 8 6 1 7 5 0 1 1 1 \*

2. (continued)

The hook is shown below.



The hook must be annealed before bending to shape.

(j) Describe the process of annealing metal.

2

---

---

---

The tools shown below were used to cut the external thread on the hook.

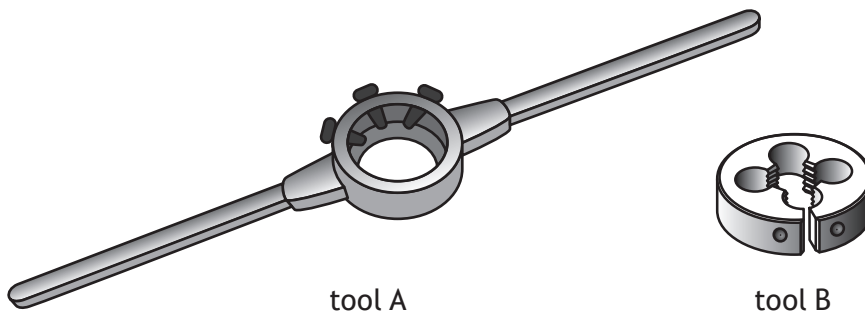

(k) Name each of the tools shown.

(i) Tool A \_\_\_\_\_

1

(ii) Tool B \_\_\_\_\_

1



3. A centre finder is shown below.  
It is made up of two parts with a nut and bolt joining them together.

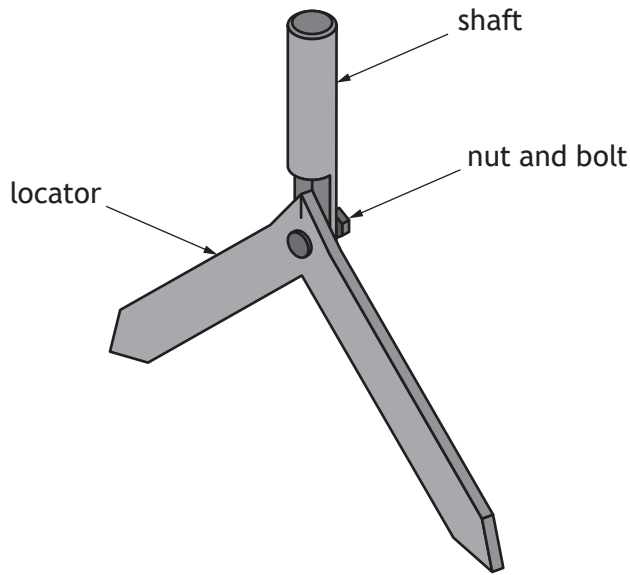

The locator is made from 3 mm thick mild steel and is marked out as shown below.

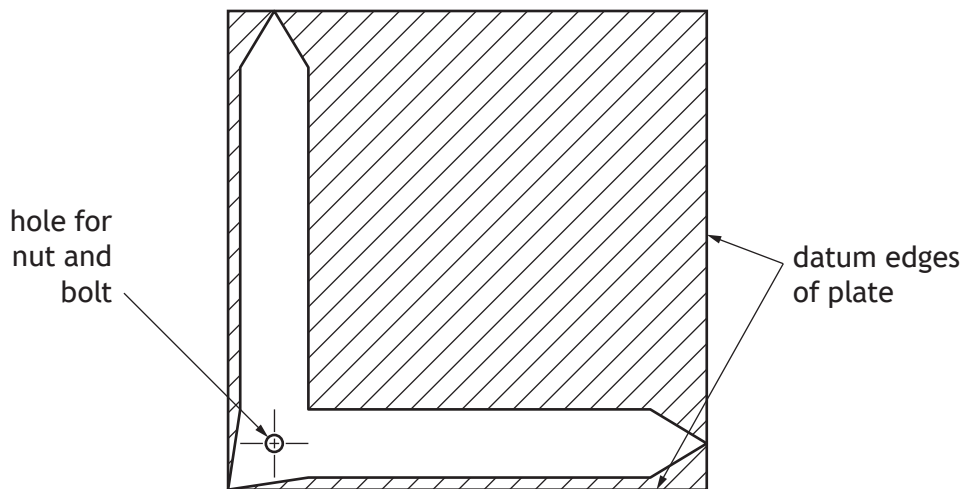

- (a) Explain why the metal was centre punched before drilling the hole. 1

---



---

- (b) Name the hand tool that would be used to remove the majority of the waste material. 1

---



3. (continued)

The tool shown below was used in the manufacture of the centre finder.

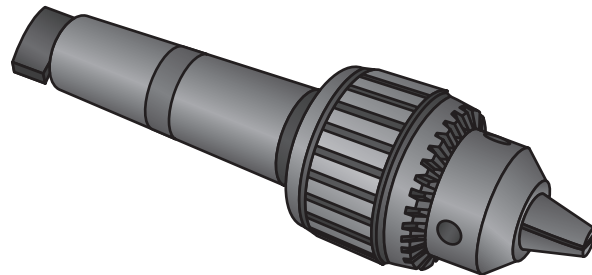

(c) (i) Name this tool.

1

---



---

(ii) Describe the purpose of this tool.

1

---

When drilling metal, twist drills should be set at an appropriate speed.

(d) Identify which twist drill should be set at a higher speed when drilling metal, by ticking (✓) a box below.

1



12 mm twist drill



3 mm twist drill



\* X 8 6 1 7 5 0 1 1 4 \*

## 3. (continued)

When drilling, swarf is created.



- (e) Name one safety precaution that should be taken when clearing swarf after drilling. 1

---

---

- (f) A painted finish is applied to the centre finder.

- (i) Explain one reason why this is a suitable finish. 1

---

---

- (ii) Describe one method of applying paint to the centre finder. 1

---

---

---

[Turn over



\* X 8 6 1 7 5 0 1 1 5 \*

3. (continued)

Two dimensions from the shaft are shown on the drawing below.  
Dimensional tolerances from the title block are also shown.

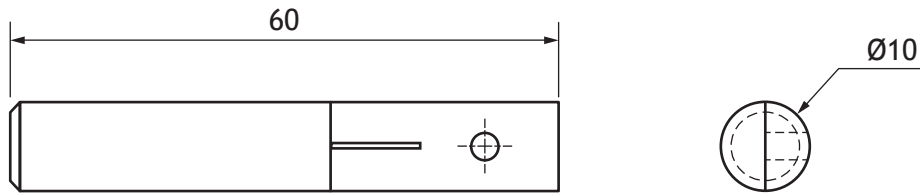

Elevation

End Elevation

Dimensional tolerances	
±0.5mm linear	
±0.2mm diameter	

- (g) (i) Identify the reading which is within tolerance when checking the Ø10mm dimension, by ticking (✓) a box below.

1

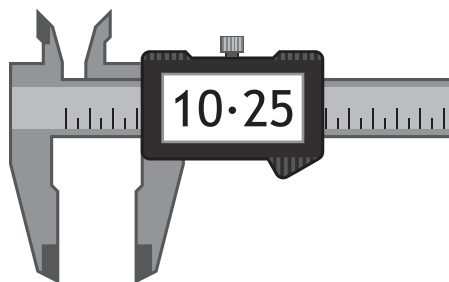

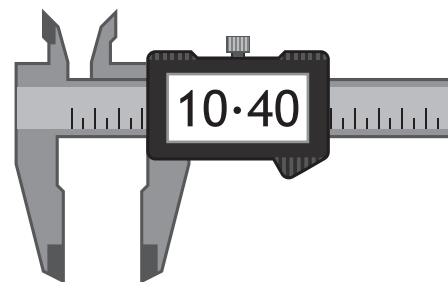

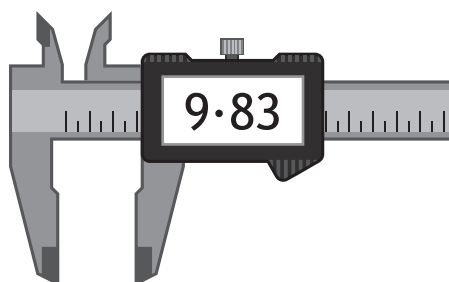

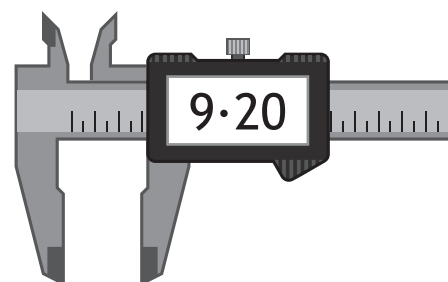





3. (g) (continued)

(ii) Identify the reading which is within tolerance when checking the 60 mm dimension, by ticking (✓) a box below.

1

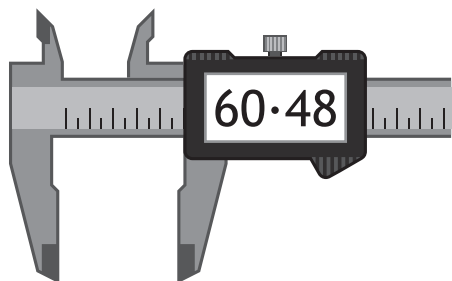

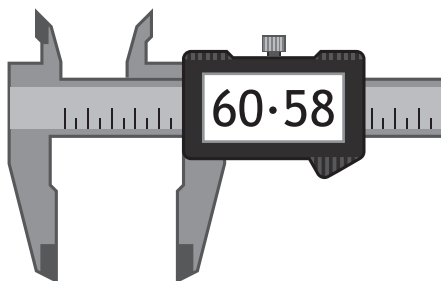

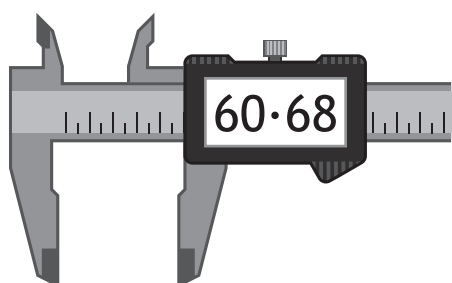

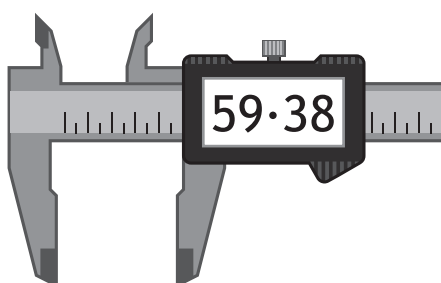



[Turn over

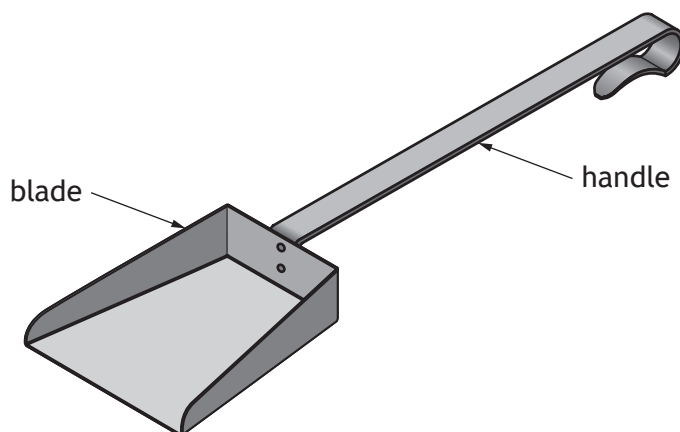

\* X 8 6 1 7 5 0 1 1 7 \*

4. A metal shovel, made from two parts, is shown below.



(a) All parts of the shovel are manufactured from the same metal.

(i) Explain why this is an advantage when recycling.

1

---

---

(ii) State one reason why recycling metal is important.

1

---

---

4. (continued)

The blade has to be marked out as shown on the drawing below.

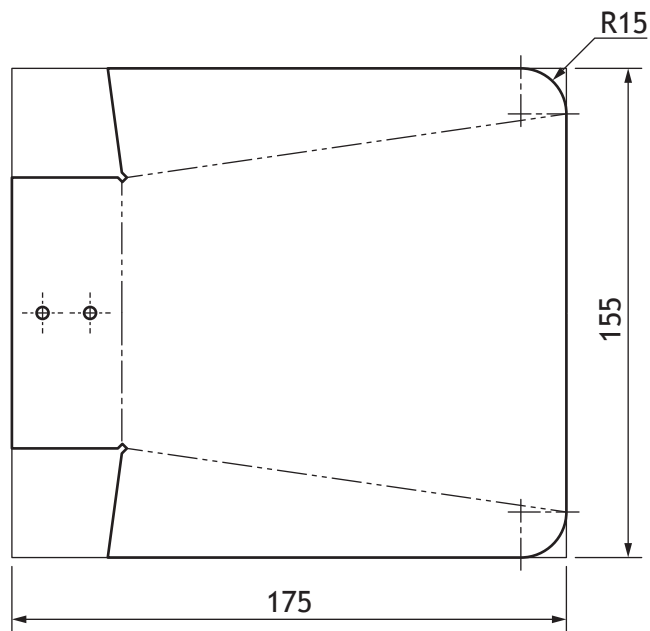

- (b) Describe how to accurately mark the R15, on the corners of the blade. 5  
 You must make reference to all tools, processes and relevant dimensions.  
 You may use sketches to support your answer.

4. (continued)

It is good practice to use a centre punch to lightly mark lines after scribing, as shown below.

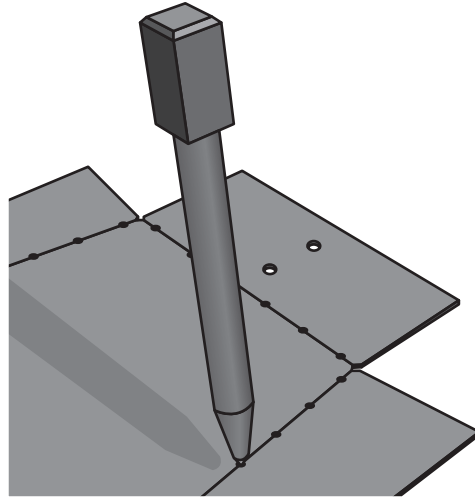

(c) State the name of this process.

1

---

(d) State two safety checks that should be carried out on a pedestal/pillar drill prior to switching on.

2

1 

---

---

2 

---

---



\* X 8 6 1 7 5 0 1 2 0 \*

## 4. (continued)

After drilling, one of the holes ended up with a ragged edge on the underside of the material as shown below.

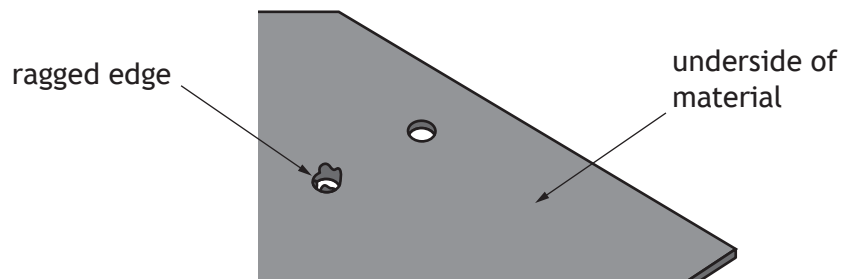

(e) Describe how to remove the ragged edge.

1

---

---

[Turn over



## 4. (continued)

The corners of the shovel blade are to be joined by brazing as shown below.

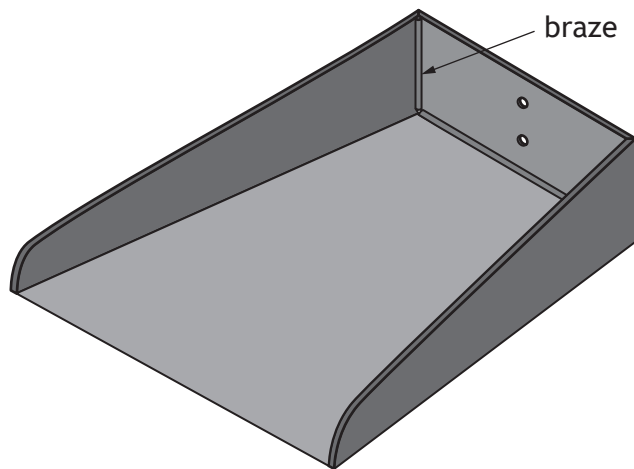

- (f) Describe the process of brazing the corners.  
You may use sketches to support your answer.

4

A large, empty rectangular box provided for the student to draw or sketch the brazing process.



MARKS

DO NOT  
WRITE IN  
THIS  
MARGIN

4. (continued)

The shovel is to be finished by bluing.

(g) Describe the process of bluing.

2

---

---

---

[Turn over



\* X 8 6 1 7 5 0 1 2 3 \*

4. (continued)

(h) The handle and the blade are joined together by the process of riveting as shown below.

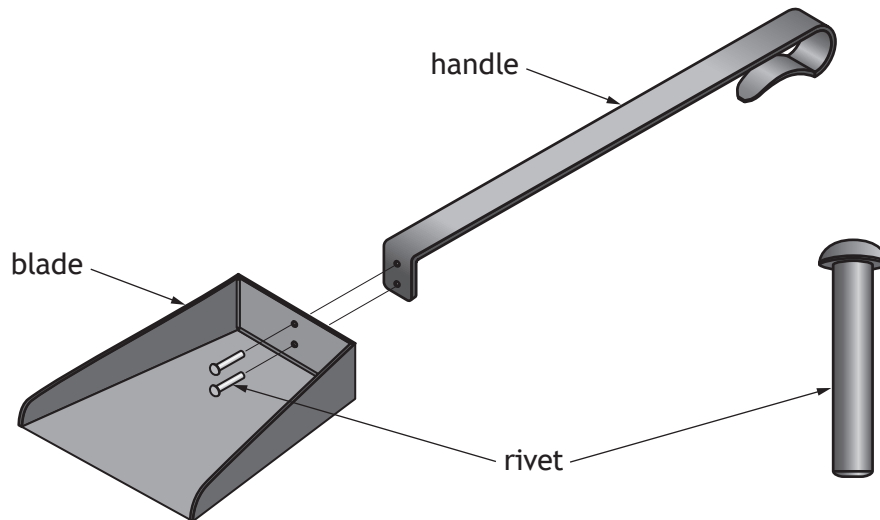

(i) Name the type of rivet shown.

1

\_\_\_\_\_

\_\_\_\_\_

(ii) Complete the procedure for describing how the blade is riveted to the handle.

2

1 Cut the rivet to the correct length.

2 \_\_\_\_\_

\_\_\_\_\_

3 Swell the rivet with the flat face of the hammer.

4 Form the rivet head with the ball pein of the hammer.

5 \_\_\_\_\_

\_\_\_\_\_







4. (continued)

- (i) Complete the table below by either describing the purpose of the tool or stating the name of the tool.

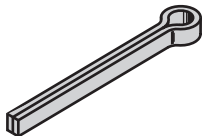
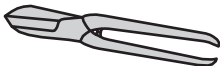
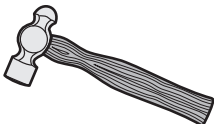
5

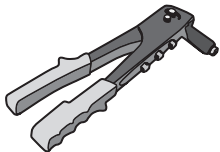
Tools	Purpose of tool	Name of tool
		Folding bars
		Tin snips
	To strike metal or other tools or to shape metal.	
		Hide mallet
	To join two pieces of sheet metal together through pre drilled holes.	

[END OF QUESTION PAPER]



\* X 8 6 1 7 5 0 1 2 5 \*

MARKS

DO NOT  
WRITE IN  
THIS  
MARGIN

ADDITIONAL SPACE FOR ANSWERS



\* X 8 6 1 7 5 0 1 2 6 \*

MARKS

DO NOT  
WRITE IN  
THIS  
MARGIN

ADDITIONAL SPACE FOR ANSWERS



\* X 8 6 1 7 5 0 1 2 7 \*

[BLANK PAGE]

DO NOT WRITE ON THIS PAGE

*Acknowledgement of copyright*

Question 2      antoniodiaz/shutterstock.com

Question 3 (e)    Lukas Gojda/shutterstock.com



\* X 8 6 1 7 5 0 1 2 8 \*