

FOR OFFICIAL USE



National
Qualifications
2018

Mark

X861/75/01

Practical Metalworking

THURSDAY, 31 MAY

2:00 PM – 3:00 PM



* X 8 6 1 7 5 0 1 *

Fill in these boxes and read what is printed below.

Full name of centre

Town

Forename(s)

Surname

Number of seat

Date of birth

Day

Month

Year

Scottish candidate number

Total marks — 60

Attempt ALL questions.

Write your answers clearly in the spaces provided in this booklet. Additional space for answers is provided at the end of this booklet. If you use this space you must clearly identify the question number you are attempting.

Use **blue** or **black** ink.

Before leaving the examination room you must give this booklet to the Invigilator; if you do not, you may lose all the marks for this paper.



* X 8 6 1 7 5 0 1 0 1 *

Total marks — 60
Attempt ALL questions

1. A handmade screwdriver, made of two separate parts, is shown below.

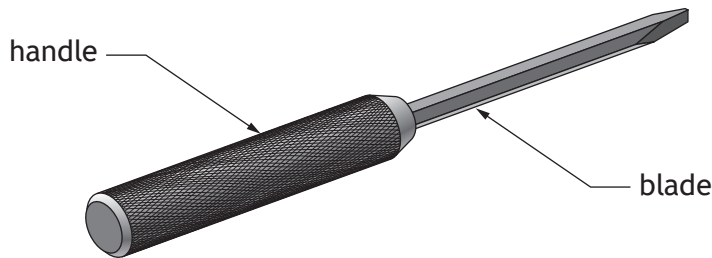

The blade is made from high carbon steel. High carbon steel is a ferrous metal.

(a) Explain what is meant by the term 'ferrous metal'. 1

(b) State one property of high carbon steel that makes it suitable for the screwdriver blade. 1

When material is delivered to a metal workshop, it comes in a range of sections.

(c) Name each of the two common sections shown below.

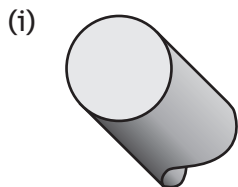

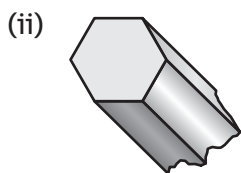
1

1

1. (continued)

(d) The screwdriver blade was hardened and then tempered.

(i) Describe the process of **hardening** the screwdriver blade.

3

(ii) Explain the effect of **tempering** the screwdriver blade.

1

The tools shown below were used during the manufacture of the screwdriver handle.

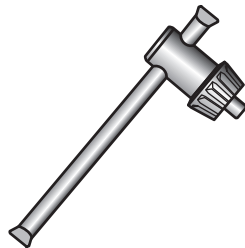

Tool A

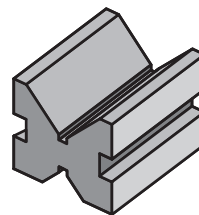

Tool B

(e) Name each of the tools shown.

(i) Tool A _____

1

(ii) Tool B _____

1

[Turn over



* X 8 6 1 7 5 0 1 0 3 *

1. (continued)

The machine shown below was used in the manufacture of the screwdriver handle.

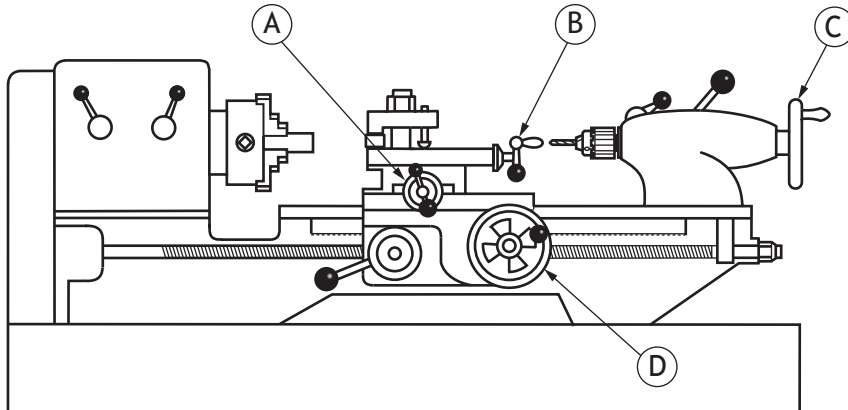

(f) Name this machine.

1

(g) Describe three safety checks that should be carried out on this machine **before** switching it on.

3

1 _____

2 _____

3 _____



1. (continued)

Handles A, B, C and D, shown on the machine opposite, were used during the manufacture of the screwdriver.

(h) Identify the correct handle to use when carrying out the processes shown below.

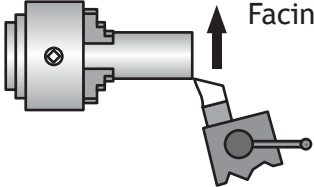
(i)  Facing off Handle _____ 1

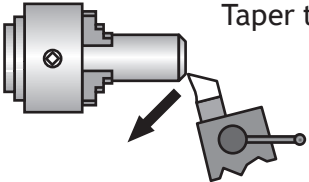
(ii)  Taper turning Handle _____ 1

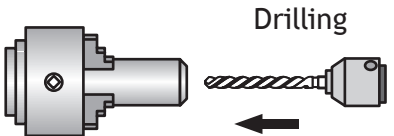
(iii)  Drilling Handle _____ 1

A 3-jaw chuck for holding the handle is shown below.

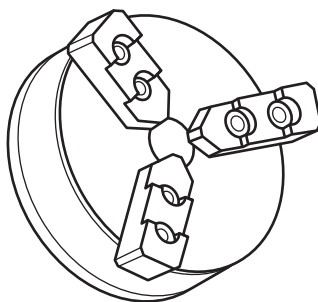

(i) State the feature of a 3-jaw chuck which makes it suitable for holding the screwdriver handle. 1

1. (continued)

The knurling tool, shown below, was used during the manufacture of the screwdriver handle.

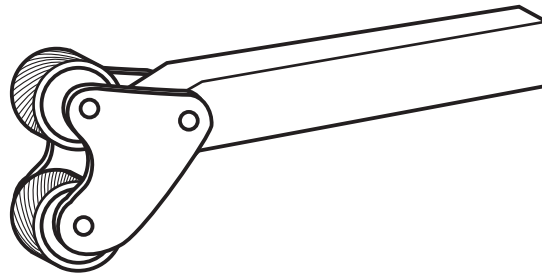

- (j) State two procedures that ensure a high quality finish is achieved when knurling.

2

1 _____

2 _____



* X 8 6 1 7 5 0 1 0 6 *

1. (continued)

The micrometer, shown below, was used to check diameters during the manufacture of the screwdriver handle.

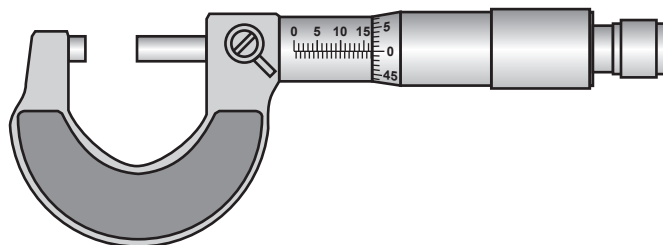

Two readings from the micrometer are shown below.

(k) State the correct readings.

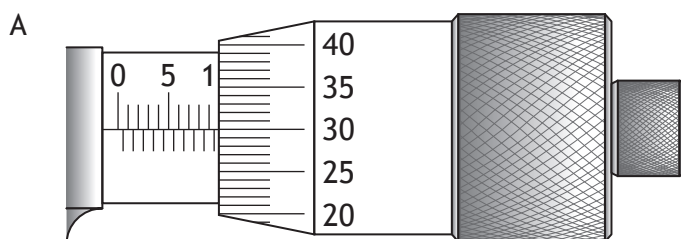

(i) Reading A _____ 1

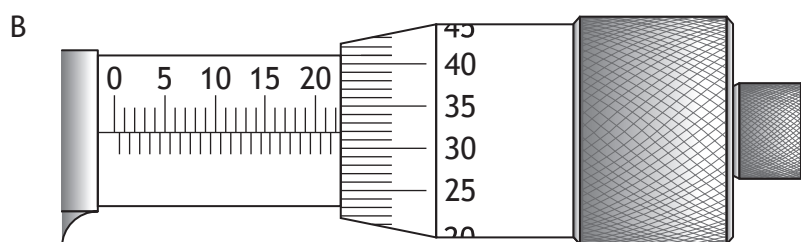

(ii) Reading B _____ 1

[Turn over



2. A handmade door knocker is shown below.

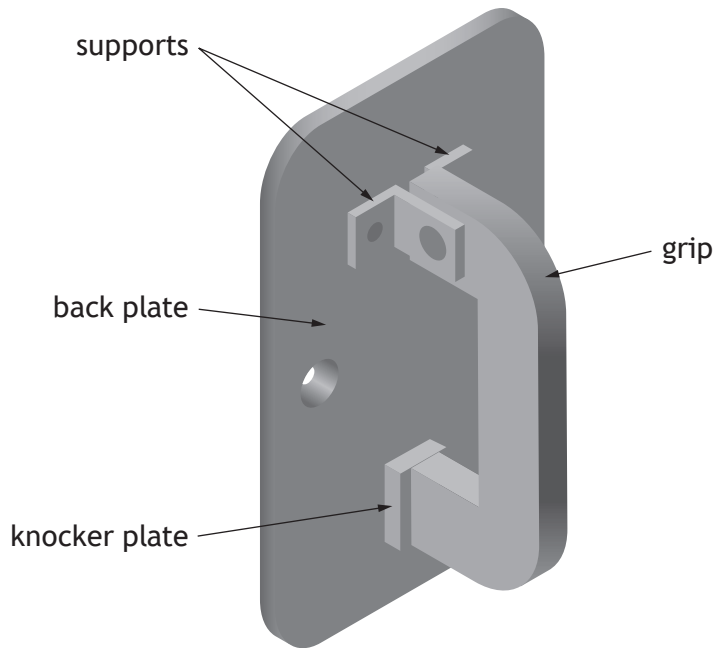

The back plate has to be marked out, as shown on the drawing below.

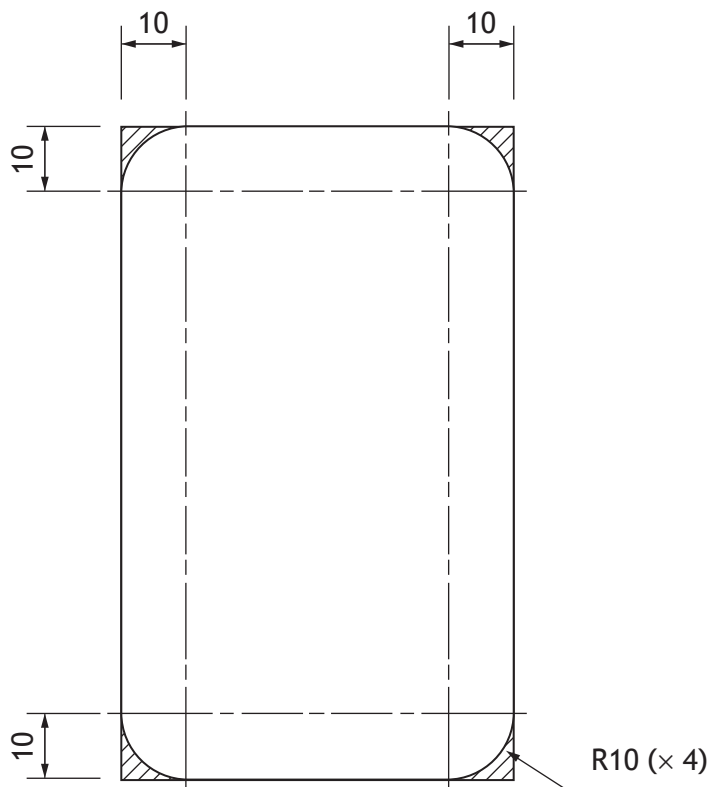

2. (continued)

- (a) (i) Describe how to accurately mark the R10 on the corners of the back plate.

5

You must make reference to all tools, processes and relevant dimensions.

You may use sketches to support your answer.

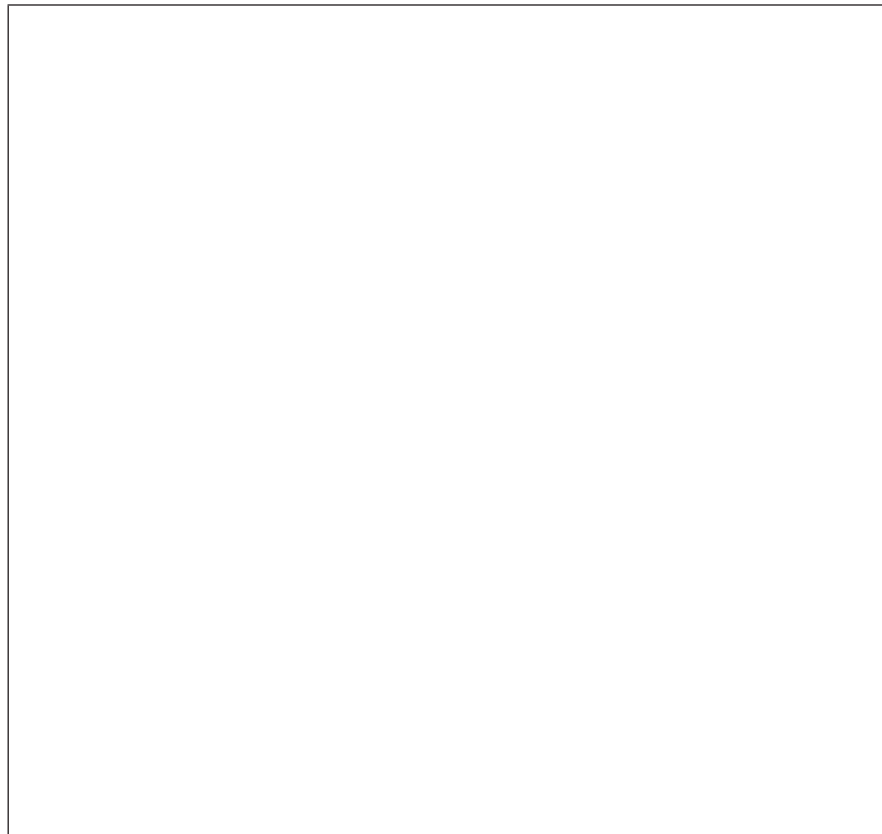

A cross section of the back plate showing the hole for a countersink screw is shown below.

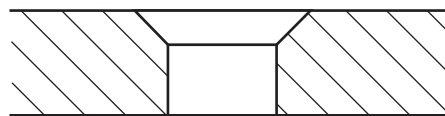

- (ii) Explain the purpose of using a countersink screw.

1



2. (continued)

This drawing shows how the grip was marked out, prior to removing the waste material.

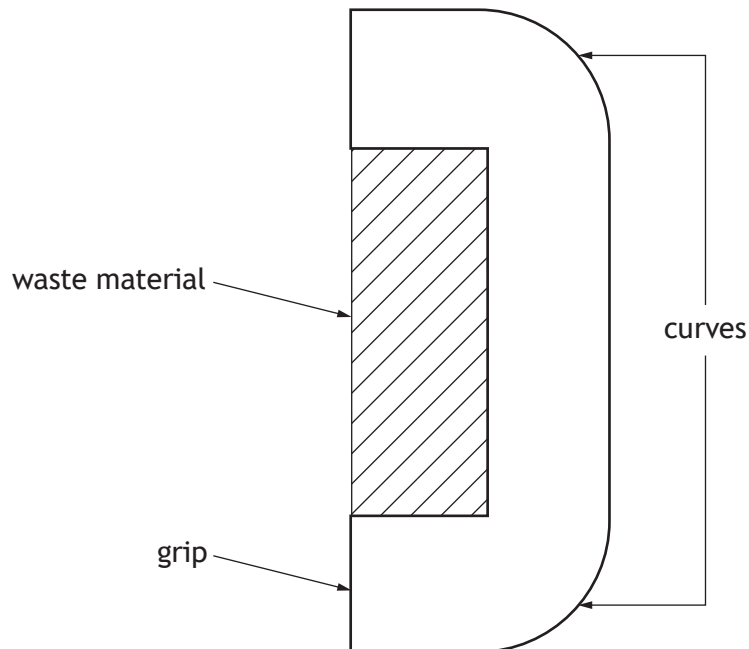

- (b) (i) Describe how to remove the waste material.
You must make reference to all tools and processes.
You may use sketches to support your answer.

3

2. (b) (continued)

A flat file was used to shape the curves. Parts of a flat file are shown below.

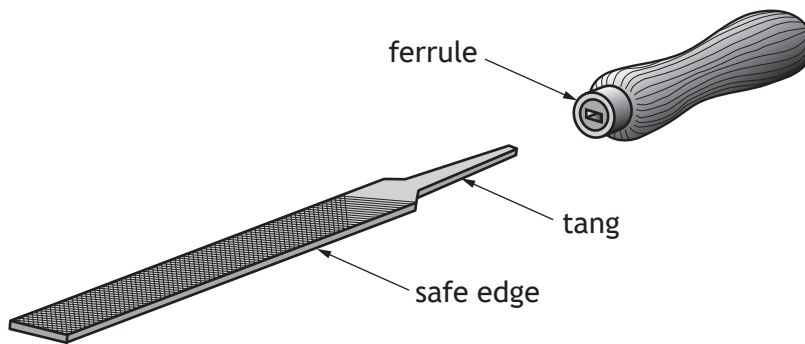

(ii) State the purpose of the following parts of the flat file.

3

Ferrule _____

Tang _____

Safe edge _____

[Turn over



2. (continued)

The supports are joined to the back plate using rivets.

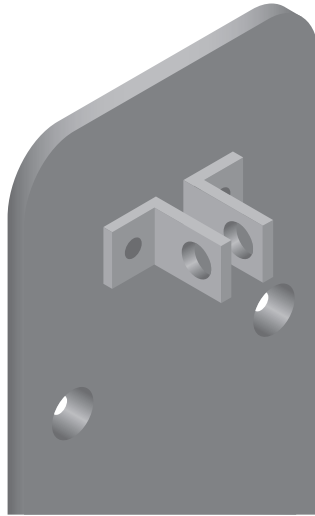

(c) Name the types of rivet shown below.



Rivet type _____ 1



Rivet type _____ 1

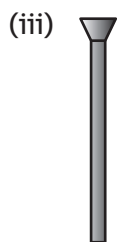

Rivet type _____ 1



2. (continued)

The tools shown below are used during riveting.



Tool A

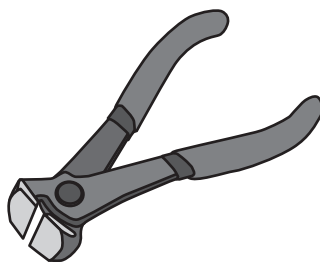

Tool B

(d) (i) Name Tool A. 1

(ii) Explain what Tool B is used for. 1

[Turn over



2. (continued)

The working drawings for the door knocker are shown below.

Back plate

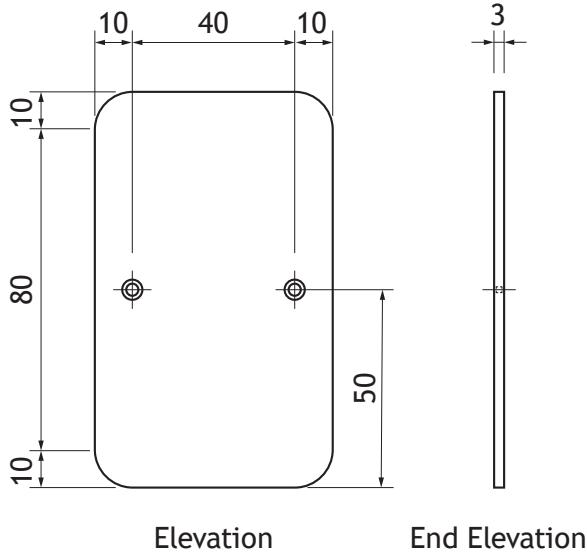

Grip

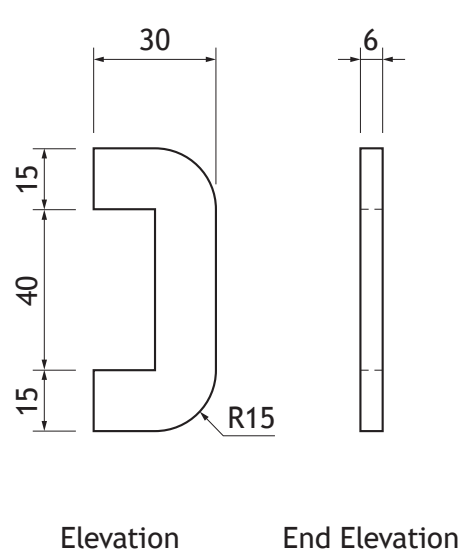

Knocker plate

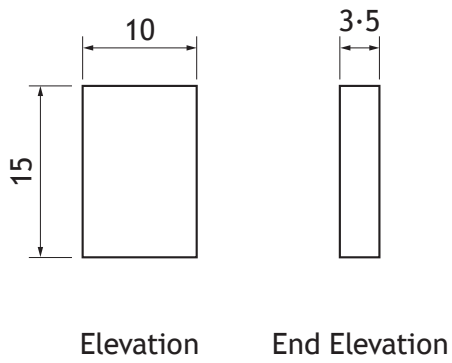

Support

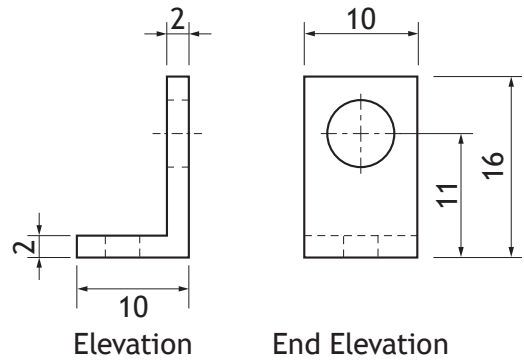

* X 8 6 1 7 5 0 1 1 4 *

2. (continued)

- (e) Using the information from the drawings shown opposite, complete the cutting list shown below.

4

Part	Number	Material	Length	Breadth	Thickness
Back plate	1	Mild steel	100		3
Grip	1	Mild steel		30	6
Support		Mild steel	26	10	2
Knocker plate	1	Mild steel	15		3.5

[Turn over



* X 8 6 1 7 5 0 1 1 5 *

2. (continued)

The tool, shown below, was used in the manufacture of the door knocker.

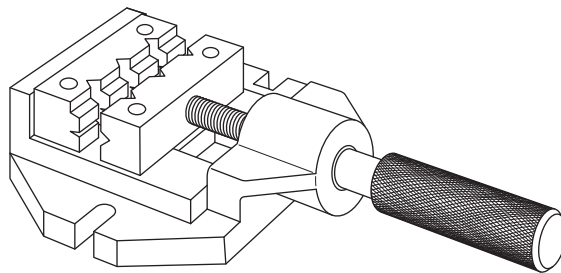

(f) Name this tool.

1

The machine, shown below, was used in the manufacture of the door knocker.

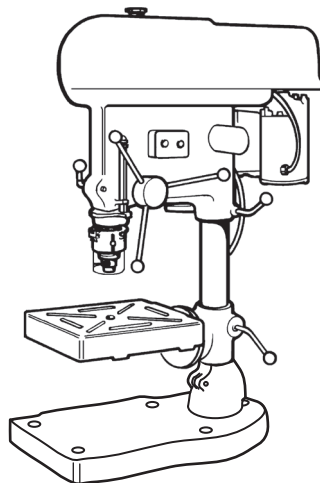

(g) Name this machine.

1

(h) Explain why work areas and floors around machinery should always be kept clean and dry.

1



3. A candle holder is shown below.

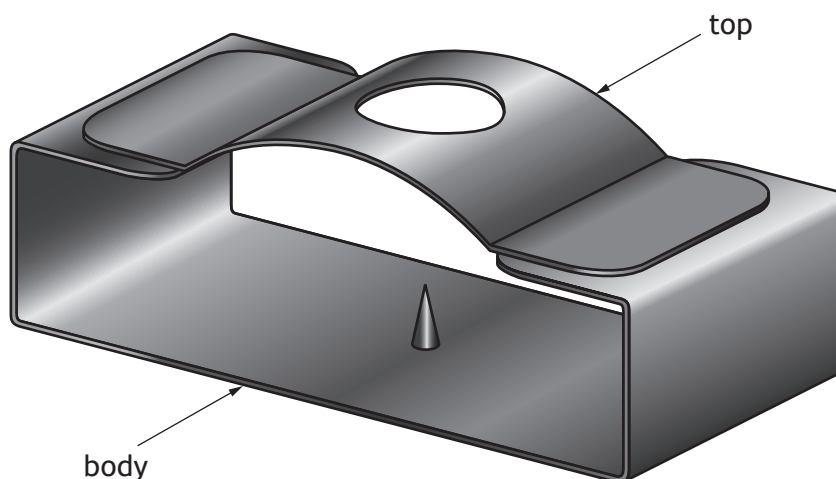

The candle holder was made from recycled metal.

- (a) (i) State why it is important to use recycled metal whenever possible. Give two reasons. 2

Reason 1 _____

Reason 2 _____

- (ii) Describe a test that would distinguish between mild steel and aluminium as part of the recycling process. 1

[Turn over



3. (continued)

The body, shown below, was made from 1mm mild steel sheet.

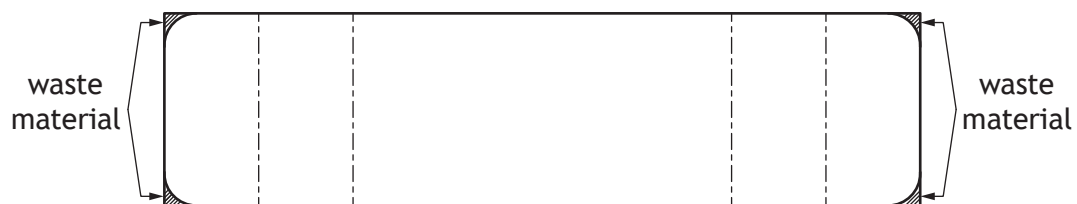

- (b) Name a hand tool that can be used to remove the waste material before finishing with a file.

1



* X 8 6 1 7 5 0 1 1 8 *

3. (continued)

The surface development and stage one of bending the body are shown below.

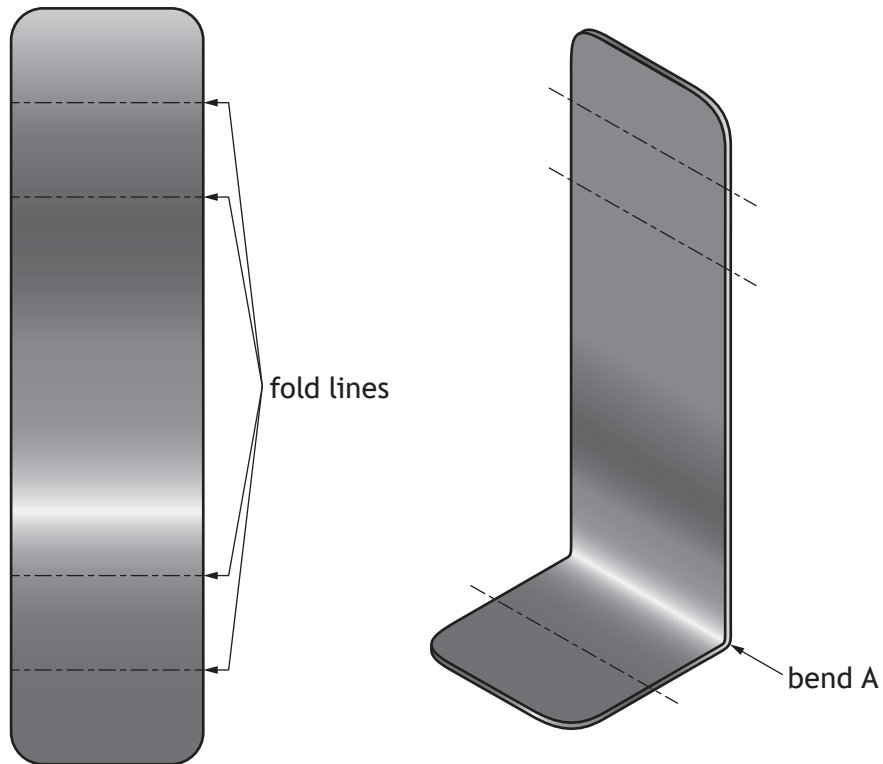

surface development

stage one of bending

- (c) Describe, using correct terminology, how bend A is formed.
You may use sketches to support your answer.

2

3. (continued)

The top of the candle holder is shown below.



- (d) Explain why the hole is drilled in the top before bending it to shape. 1

It was decided to make a pair of candle holders.

- (e) State a method of ensuring that both tops are bent to the same shape. 1

- (f) State one health and safety precaution that should be taken when working with sheet metal. 1



3. (continued)

The tool shown below is used when working with sheet metal.

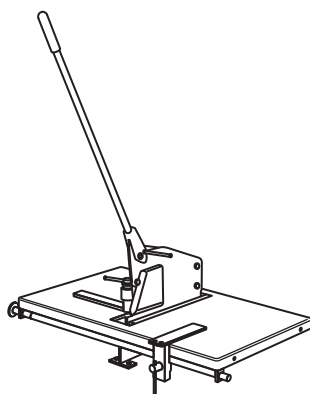

(g) Name this tool. 1

(h) Describe two stages of preparing sheet metal for a finish. 2

1 _____

2 _____

(i) State a suitable finish which could be applied to sheet metal. 1

(j) Explain why blunt tools can be just as hazardous as sharp tools. 1

[END OF QUESTION PAPER]



* X 8 6 1 7 5 0 1 2 1 *

MARKS

DO NOT
WRITE IN
THIS
MARGIN

ADDITIONAL SPACE FOR ANSWERS



* X 8 6 1 7 5 0 1 2 2 *

MARKS

DO NOT
WRITE IN
THIS
MARGIN

ADDITIONAL SPACE FOR ANSWERS



* X 8 6 1 7 5 0 1 2 3 *

[BLANK PAGE]

DO NOT WRITE ON THIS PAGE



* X 8 6 1 7 5 0 1 2 4 *