

FOR OFFICIAL USE



National  
Qualifications  
2024

Mark

X844/75/01

# Applications of Mathematics Paper 1 (Non-calculator)

MONDAY, 13 MAY  
9:00 AM – 9:50 AM



\* X 8 4 4 7 5 0 1 \*

Fill in these boxes and read what is printed below.

Full name of centre

Town

Forename(s)

Surname

Number of seat

Date of birth

Day

Month

Year

Scottish candidate number

Total marks — 35

Attempt ALL questions.

You must NOT use a calculator.

To earn full marks you must show your working in your answers.

State the units for your answer where appropriate.

Write your answers clearly in the spaces provided in this booklet. Additional space for answers is provided at the end of this booklet. If you use this space you must clearly identify the question number you are attempting.

Use blue or black ink.

Before leaving the examination room you must give this booklet to the Invigilator; if you do not, you may lose all the marks for this paper.



\* X 8 4 4 7 5 0 1 0 1 \*

## FORMULAE LIST

Circumference of a circle  $C = \pi d$

Area of a circle  $A = \pi r^2$

Theorem of Pythagoras

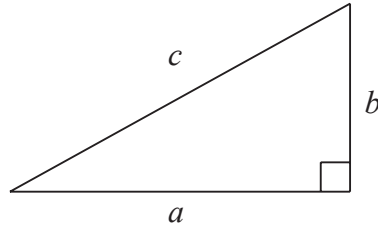

$$a^2 + b^2 = c^2$$

Volume of a cylinder  $V = \pi r^2 h$

Volume of a prism  $V = Ah$

Volume of a cone  $V = \frac{1}{3} \pi r^2 h$

Volume of a sphere  $V = \frac{4}{3} \pi r^3$

Standard deviation  $s = \sqrt{\frac{\sum(x - \bar{x})^2}{n - 1}}$

or  $s = \sqrt{\frac{\sum x^2 - \frac{(\sum x)^2}{n}}{n - 1}}$ , where  $n$  is the sample size.

Gradient

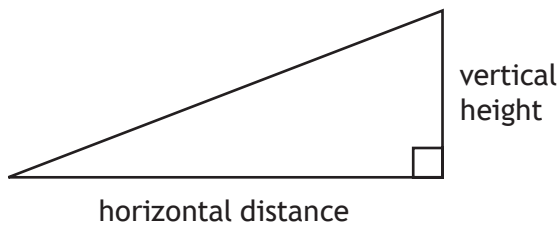

$$\text{gradient} = \frac{\text{vertical height}}{\text{horizontal distance}}$$



Total marks — 35  
Attempt ALL questions

1. Ella's temperature on Wednesday was 37.5 °C.  
Ella's temperature on Thursday was 98 °F.

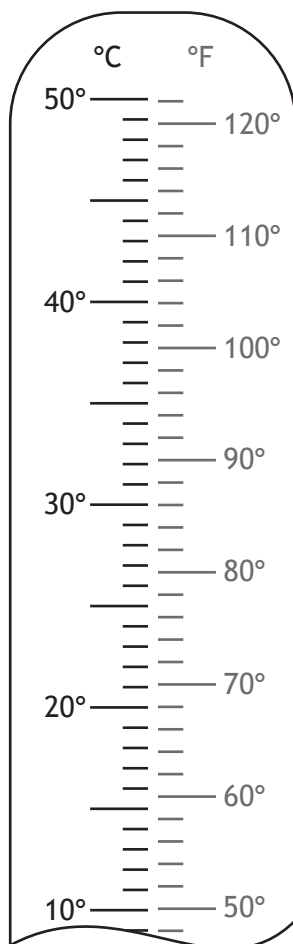

Mark both temperatures on the thermometer **and** determine on which day she had the higher temperature.

(An additional diagram, if required, can be found on *page 14*.)

2

[Turn over



2. Hamish is doing scientific research involving foals (baby horses).  
For his research, Hamish must use foals that weigh  $49.5 \text{ kg} \pm 2 \text{ kg}$ .  
Below are the weights of 20 foals, in kilograms.

49.5	46.9	47.9	51.6	49.7
49.4	51.5	47.0	48.6	50.6
51.8	48.8	48.0	47.5	50.0
51.4	47.4	51.0	49.1	47.6

Calculate the percentage of foals that Hamish **cannot** use for his research.

3



\* X 8 4 4 7 5 0 1 0 4 \*

3. Lee is saving up to buy a laptop costing £470.  
 He earns £11.50 per hour and works 30 hours each week.  
 Lee is paid weekly.  
 He pays £20.25 in tax and £12.35 in National Insurance each week.  
 He spends £42.40 each week on rail fares.  
 Lee saves  $\frac{1}{3}$  of his remaining money towards the laptop.  
 Calculate how many weeks it will take Lee to save enough money to buy the laptop. **3**

[Turn over



4. Stephen has built a new ramp.

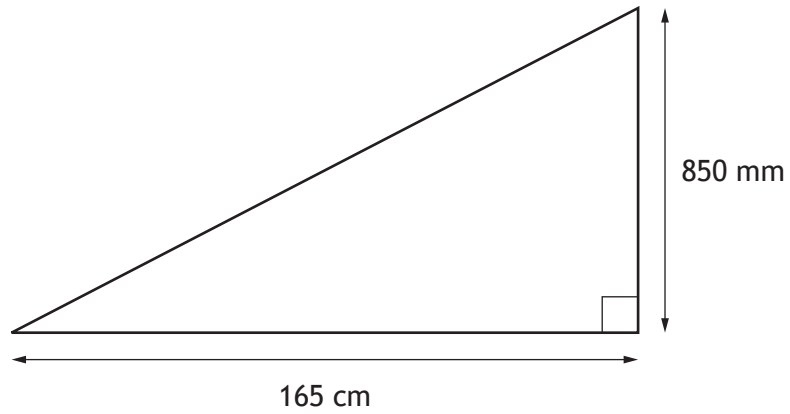

Calculate the gradient of the ramp.

Give your answer as a fraction in its simplest form.

2

5. The number of films Megan downloaded each month for a year is shown.

34 19 22 10 13 38 9 12 26 7 19 21

(a) (i) For this data, calculate:

- the median
- the lower quartile
- the upper quartile.

2

(ii) Construct a boxplot for this data.

(An additional diagram, if required, can be found on *page 14*.)

2

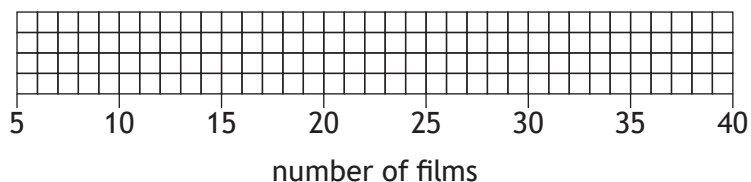

(b) (i) Calculate the interquartile range for the number of films Megan downloaded.

1

Tommy also recorded the number of films he downloaded each month.

The interquartile range for the number of films Tommy downloaded is 10.

(ii) Make one valid comment comparing the number of films Megan and Tommy downloaded.

1

[Turn over



6. Jamie bought 2 identical cakes for his birthday.

His friends ate  $\frac{2}{3}$  of the first cake.

His family ate  $\frac{3}{4}$  of the second cake.

Calculate the **total** amount of cake left over.

Give your answer as a fraction of a cake.

3





7. A container consists of a cuboid and a triangular prism.

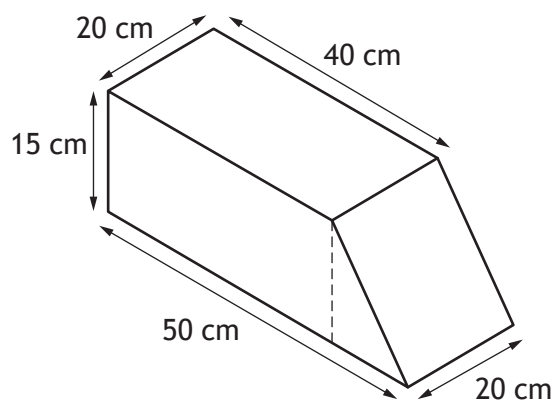

Calculate the volume of the container.  
Give your answer in litres.

3

[Turn over



8. Tabitha is a van driver for a supermarket that provides home deliveries. Orders are packed into boxes for home delivery to customers. The dimensions of each box and the internal dimensions of the van are shown in the diagrams.

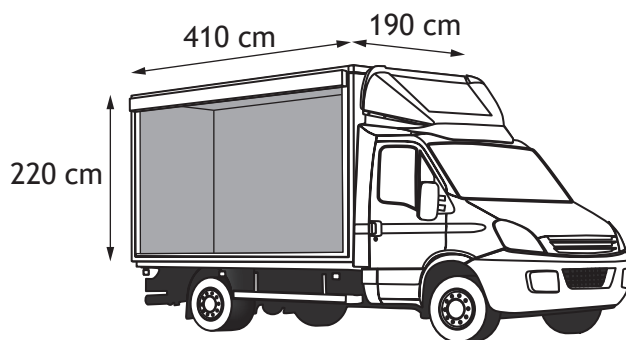
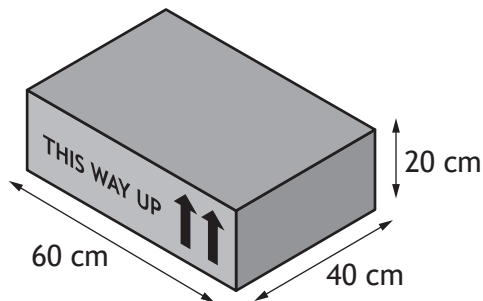

All boxes must be aligned in the same direction.

Calculate the maximum number of boxes that will fit in the van.

3



9. A banner is being edged with ribbon.  
It is in the shape of a rectangle and two quarter circles.

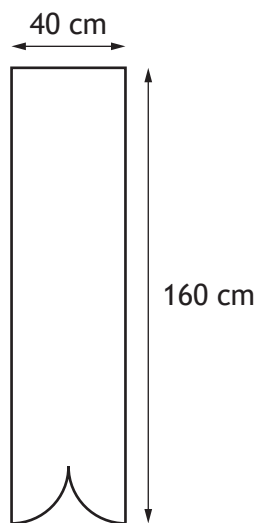

Calculate the length of ribbon needed to edge the banner.

Use  $\pi = 3.14$ .

2

[Turn over



10. In 2022 and 2023 all S4 pupils at Lowgrove Academy achieved a Numeracy qualification.

The results for S4 pupils in 2022 are shown in the pie chart.

2022 Numeracy results

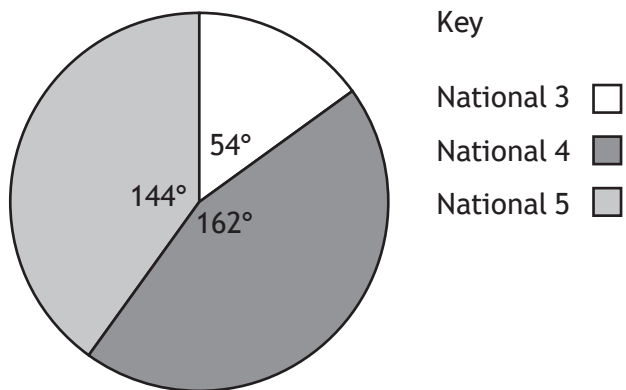

The results for S4 pupils in 2023 are shown in the table.

Qualification	Number of pupils
National 3	18
National 4	52
National 5	50

Determine if there has been an increase in the proportion of pupils achieving National 5 Numeracy.

Use your working to justify your answer.

3



\* X 8 4 4 7 5 0 1 1 2 \*

11. A helicopter was hired to drop passengers off at two separate locations. It flew 60 km on a bearing of  $227^\circ$  to the first location. It then flew 45 km on a bearing of  $152^\circ$  to the second location.

- (a) Construct a scale drawing to illustrate this journey.  
Use a scale of 1 cm : 10 km.

3



The helicopter then returns to the start from the second location.

- (b) Use your scale drawing to determine the distance and bearing of the start from the second location.

(An additional diagram, if required, can be found on *page 15*.)

2

[END OF QUESTION PAPER]



ADDITIONAL SPACE FOR ANSWERS

Additional diagram for use with question 1

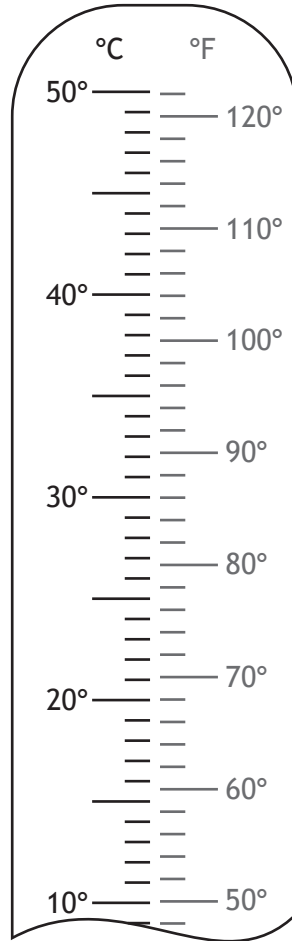

Additional diagram for use with question 5 (a) (ii)

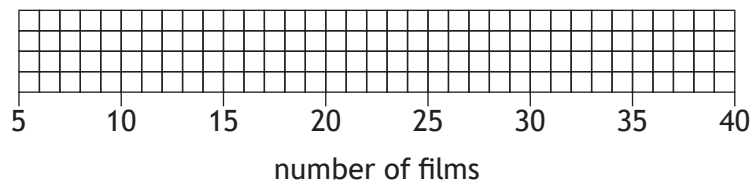

ADDITIONAL SPACE FOR ANSWERS

Additional diagram for use with question 11



**MARKS** DO NOT  
WRITE IN  
THIS  
MARGIN

ADDITIONAL SPACE FOR ANSWERS

