



Higher
Coursework
Assessment Task



Higher Design and Manufacture Assignment Assessment task

Valid for session 2024-25 only.

This assessment is given to centres in strictest confidence. You must keep it in a secure place until it is used.

The information in this publication may be reproduced in support of SQA qualifications only on a non-commercial basis. If it is reproduced, SQA must be clearly acknowledged as the source. If it is to be reproduced for any other purpose, written permission must be obtained from permissions@sqa.org.uk.

This edition: November 2024 (version 1.0)

© Scottish Qualifications Authority 2024

Contents

Introduction	1
Instructions for teachers and lecturers	2
Marking instructions	5
Instructions for candidates	17
Design briefs	24

Introduction

This document contains instructions for teachers and lecturers, marking instructions and instructions for candidates for the Higher Design and Manufacture assignment. You must read it in conjunction with the course specification.

This assignment has 90 marks out of a total of 170 marks available for the course assessment.

This is one of two course assessment components. The other component is a question paper.

Instructions for teachers and lecturers

Setting, conducting and marking the assignment

This assignment assesses the candidate's ability to apply design skills to develop a proposal for a design brief.

It allows candidates to demonstrate their ability to work independently, and is sufficiently open and flexible to allow personalisation and choice.

The assignment is:

- ◆ set and marked by SQA
- ◆ conducted in centres under conditions specified by SQA

Evidence for the assessment is submitted to SQA.

Before candidates undertake the assignment, they should have the necessary design skills and be aware of the requirements of the assessment. You should give candidates the 'Instructions for candidates', which are at the end of this document.

Candidates must be given:

- ◆ a choice of three briefs
- ◆ a 'research' pro forma
- ◆ a 'research and specification' pro forma
- ◆ a 'planning for commercial manufacture' pro forma
- ◆ a 'practical modelling skills' pro forma

Candidates are required to develop a proposal for **one** of the design briefs. They are assessed on:

Area	Marks
◆ carrying out research into a given brief	5 marks
◆ producing a specification	3 marks
◆ generating initial ideas	8 marks
◆ exploring ideas	12 marks
◆ refining ideas	6 marks
◆ applying knowledge and understanding of materials and assembly processes	10 marks
◆ applying knowledge and understanding of design	12 marks
◆ applying graphic techniques	12 marks
◆ applying modelling techniques	8 marks
◆ demonstrating practical modelling skills	8 marks
◆ producing a plan for commercial manufacture	6 marks

Assessment conditions

Time

Candidates produce evidence for the assignment over an extended period, allowing them to develop and refine their work before it is presented for assessment.

Supervision, control and authentication

You must ensure that evidence submitted by a candidate is their own work. You do not need to directly supervise candidates at all times, and you must retain candidates' work between assessment sessions.

Resources

There are no restrictions on the resources that candidates can access while producing their assignment.

Reasonable assistance

Candidates must carry out the assessment independently. However, you can provide reasonable assistance prior to the assessment. The assignment must be carried out without interruption by periods of learning and teaching.

If a candidate encounters difficulties at a particular part of a task, it is reasonable for you to refer them to material covered in the course. You can also give candidates information on the range of materials that the centre can supply.

Candidates can ask for clarification of the wording of a brief if they find it unclear. In this case, you should normally provide this to the whole class. However, it is reasonable for you to ask candidates to re-read the brief and/or their specification, giving them the opportunity to progress without providing them with specific information.

You must **not** provide candidates with:

- ◆ any additional information for the task, for example, research material or specification points
- ◆ a structured layout for the folio, for example, a pro forma with headings and/or descriptions of sections
- ◆ an exemplar response similar to the task
- ◆ alternative ideas or solutions to encourage or enhance exploration
- ◆ specific advice, including any advice that would allow candidates to gain marks for work that is not their own, such as:
 - specific information on areas to research
 - advice on which research technique(s) to use
 - advice on which idea-generation technique(s) to use
 - starting points for ideas
 - sketches
 - suggestions on presenting evidence
 - specific information on commercial manufacturing

The use of generative artificial intelligence is not permitted. Please see SQA's website for more information, if needed.

Evidence to be gathered

Volume

Candidates are required to develop a proposal for **one** of the design briefs. They must submit their work on a maximum of 12 A3 sheets (or equivalent), including the following four pro formas issued annually with the assignment:

- ◆ research pro forma
- ◆ research and specification pro forma
- ◆ planning for commercial manufacture pro forma
- ◆ practical modelling skills pro forma

This information indicates the volume of evidence required. There is no word count.

More information on submitting the assignment is on the Higher Design and Manufacture page of our website.

Marking instructions

In line with SQA's normal practice, the following marking instructions are addressed to the marker. They will also be helpful for those preparing candidates for course assessment.

Candidate evidence is submitted to SQA for external marking.

General marking principles

Always apply these general principles. Use them in conjunction with the detailed marking instructions, which identify the key features required in candidates' responses.

- a Always use positive marking. This means candidates accumulate marks for the demonstration of relevant skills, knowledge and understanding; marks are not deducted for errors or omissions.
- b If a specific candidate response does not seem to be covered by either the principles or detailed marking instructions, and you are uncertain how to assess it, you must seek guidance from your team leader.
- c When marking the assignment, you must refer to specific descriptions of competence for different mark ranges and allocate marks for each section using a 'best fit' approach.
- d The statements within the bands give an indication of what may appear in the evidence. Candidates do not need to meet every statement to achieve marks within a band.
- e Do not award marks where candidates' work does not meet the lowest range statement, or where they do not provide any evidence.

Detailed marking instructions

The statements within the band indicate the features that may be displayed in the evidence.

Skill: carrying out research into a given brief

Make your marking judgements based on the candidate's ability to carry out appropriate research and their use of research techniques.

Skill	Max mark	1-2 marks	3-4 marks	5 marks
Carrying out research into a given brief	5	<ul style="list-style-type: none"> ◆ few issues researched are appropriate ◆ limited use of primary and secondary research techniques 	<ul style="list-style-type: none"> ◆ most issues researched are appropriate ◆ effective use of primary and secondary research techniques 	<ul style="list-style-type: none"> ◆ issues researched are appropriate ◆ highly effective use of primary and secondary research techniques

Further information for assessing 'carrying out research into a given brief'

- ◆ Research should generate information that is suitable for a specification.
- ◆ Do not award marks for research that generates generic information. Such research is not valid.
- ◆ Research techniques must be appropriate to the information being gathered.

Skill: producing a specification

Make your marking judgements based on the candidate's ability to produce a specification that has detail and covers a range of issues.

Skill	Max mark	1 mark	2 marks	3 marks
Producing a specification	3	<ul style="list-style-type: none">◆ specification is limited in identifying the requirements of the proposal◆ specification covers a limited range of issues◆ specification contains limited detail	<ul style="list-style-type: none">◆ specification adequately identifies the requirements of the proposal◆ specification covers an adequate range of issues◆ specification contains adequate detail	<ul style="list-style-type: none">◆ specification clearly identifies the requirements of the proposal◆ specification covers a wide range of issues◆ specification is detailed

Further information for assessing 'producing a specification'

- ◆ Specification points that are drawn only from the brief will achieve a maximum of 1 mark.
- ◆ Candidates must draw their additional specification points from their research.
- ◆ Do not award marks for specification points that are based purely on the candidate's personal opinion.

Skill: generating initial ideas

Make your marking judgements based on the candidate's ability to generate a range of diverse and creative ideas that address the design brief.

Skill	Max mark	1-2 marks	3-5 marks	6-8 marks
Generating initial ideas	8	<ul style="list-style-type: none"> ◆ ideas show limited diversity ◆ ideas show limited creativity ◆ few ideas address the brief ◆ ideas have limited detail 	<ul style="list-style-type: none"> ◆ ideas show some diversity ◆ ideas show some creativity ◆ some ideas address the brief ◆ ideas have adequate detail 	<ul style="list-style-type: none"> ◆ ideas show diversity ◆ ideas show creativity ◆ ideas address the brief ◆ ideas have effective detail

Further information for assessing – 'generating initial ideas'

- ◆ Marks in this section are awarded for **initial** ideas. Award marks for additional ideas under the 'explore ideas' section.
- ◆ To demonstrate the skills at the level of the top marks band, candidates need to generate a wide range of ideas.
- ◆ Award marks for the candidate's creativity and their ability to generate diverse ideas. Do not award marks for iterations of the same idea.
- ◆ To gain marks, ideas must address the brief. For example, do not award marks for random shapes or forms.
- ◆ Do not award marks above the bottom band for copies or slight alterations of existing ideas.
- ◆ Candidates can communicate detail through graphics, models and/or annotations.

Skill: exploring ideas

Make your marking judgements based on the candidate's ability to explore ideas towards a proposal. This includes their ability to consider alternatives to evolve the proposal and the requirements of the design proposal.

Skill	Max mark	1-3 marks	4-6 marks	7-9 marks	10-12 marks
Exploring ideas	12	<ul style="list-style-type: none"> ◆ limited exploration ◆ limited consideration of alternatives ◆ few requirements of the proposal have been considered 	<ul style="list-style-type: none"> ◆ some effective exploration ◆ some consideration of alternatives ◆ some requirements of the proposal have been considered 	<ul style="list-style-type: none"> ◆ effective exploration ◆ good consideration of alternatives ◆ most requirements of the proposal have been considered 	<ul style="list-style-type: none"> ◆ highly effective exploration ◆ clear consideration of alternatives ◆ the requirements of the proposal have been considered

Further information for assessing – 'exploring ideas'

- ◆ Meaningful exploration results in improvements to initial ideas. The requirements of the brief and specification should drive the exploration. Evidence of meaningful exploration is likely to look divergent and supported by the candidate's creativity, problem-solving ability and knowledge and understanding of key areas of the course.
- ◆ Candidates can demonstrate exploration:
 - throughout the folio – evidence is likely to be graphics, photographs of models and annotations
 - through considering the requirements of the proposal
 - through considering alternatives to the key aspects, such as functional requirements, safety, ergonomics, assembly and aesthetics, to evolve the proposal
- ◆ Exploration must be meaningful. Do not award marks for simple changes, such as rounding corners.

Skill: refining ideas

Make your marking judgements based on the candidate's ability to refine ideas towards a design proposal, and the range of aspects refined.

Skill	Max mark	1-2 marks	3-4 marks	5-6 marks
Refining ideas	6	<ul style="list-style-type: none"> ◆ limited refinement of ideas ◆ limited range of aspects of the proposal has been refined ◆ limited detail to inform plan for manufacture 	<ul style="list-style-type: none"> ◆ adequate refinement of ideas ◆ adequate range of aspects of the proposal has been refined ◆ adequate detail to inform plan for manufacture 	<ul style="list-style-type: none"> ◆ thorough refinement of ideas ◆ a range of aspects of the proposal has been refined ◆ effective detail to inform plan for manufacture

Further information for assessing – 'refining ideas'

- ◆ Thorough refinement will result in a detailed proposal. Evidence of refinement is likely to be convergent and supported by the candidate's ability to test, evaluate, and apply knowledge and understanding of key areas of the course.
- ◆ Refinement should lead to a level of detail that allows the candidate to produce a plan for commercial manufacture.
- ◆ Candidates can refine a range of aspects of the proposal. These will depend on the proposal but may include function, sizes, materials, aesthetics and assembly.
- ◆ Do not award marks above the bottom band for dimensioned drawing on its own.

Skill: applying knowledge and understanding of materials, manufacturing and assembly processes

Make your marking judgements based on the candidate's ability to apply knowledge and understanding of materials, manufacturing and assembly processes to develop a design proposal.

Skill	Max mark	1-2 marks	3-5 marks	6-8 marks	9-10 marks
Applying knowledge and understanding of materials, manufacturing and assembly processes	10	<ul style="list-style-type: none"> ◆ limited use of knowledge and understanding of materials, manufacturing and assembly to evaluate and inform decisions ◆ limited knowledge and understanding of materials, manufacturing and assembly 	<ul style="list-style-type: none"> ◆ partially effective use of knowledge and understanding of materials, manufacturing and assembly to inform decisions ◆ some knowledge and understanding of materials, manufacturing and assembly 	<ul style="list-style-type: none"> ◆ effective use of knowledge and understanding of materials, manufacturing and assembly to inform decisions ◆ good knowledge and understanding of materials, manufacturing and assembly 	<ul style="list-style-type: none"> ◆ highly effective use of knowledge and understanding of materials, manufacturing and assembly to inform decisions ◆ strong knowledge and understanding of materials, manufacturing and assembly

Further information for assessing – 'applying knowledge and understanding of materials, manufacturing and assembly processes'

- ◆ Evidence can be candidate annotations, comments, justification and evaluations.
- ◆ To gain marks in the top band, candidates must demonstrate application of detailed and appropriate knowledge and understanding of materials, manufacturing and assembly processes when developing their proposal.
- ◆ Candidates should apply their knowledge and understanding of materials, manufacturing and assembly processes to develop the proposal.
- ◆ Do not award marks for generic statements about materials and processes.
- ◆ Do not award marks for a list of archived facts collected about materials and processes.

Skill: applying knowledge and understanding of design

Make your marking judgements based on the candidate's ability to apply knowledge and understanding of design to develop a design proposal.

Skill	Max mark	1-3 marks	4-6 marks	7-9 marks	10-12 marks
Applying knowledge and understanding of design	12	<ul style="list-style-type: none"> ◆ limited use of knowledge and understanding of design to inform decisions ◆ limited knowledge and understanding of design 	<ul style="list-style-type: none"> ◆ partially effective use of knowledge and understanding of design to inform decisions ◆ some knowledge and understanding of design 	<ul style="list-style-type: none"> ◆ effective use of knowledge and understanding of design to inform decisions ◆ good knowledge and understanding of design 	<ul style="list-style-type: none"> ◆ highly effective use of knowledge and understanding of design to inform decisions ◆ strong knowledge and understanding of design

Further information for assessing – 'applying knowledge and understanding of design'

- ◆ Evidence can be candidate annotations, comments, graphics and evaluations.
- ◆ To gain marks in the top band, candidates must demonstrate application of detailed and appropriate knowledge and understanding of design when developing their proposal.
- ◆ Candidates should apply their knowledge and understanding of design to develop the proposal. Do not award marks for information covered on the 'planning for commercial manufacture' pro forma.
- ◆ Do not award marks for generic statements about design.
- ◆ Do not award marks for a list of archived facts collected about design.
- ◆ To achieve marks in the top band, candidates must apply design knowledge related to the key points in the specification.

Skill: applying graphic techniques

Make your marking judgements based on the candidate's ability to apply a range of appropriate graphic techniques to communicate the development and detail of the design proposal.

Skill	Max mark	1-3 marks	4-6 marks	7-9 marks	10-12 marks
Applying graphic techniques	12	<ul style="list-style-type: none"> ◆ limited communication through graphics ◆ limited detail is communicated through graphics 	<ul style="list-style-type: none"> ◆ partially effective communication through graphics ◆ partially effective detail is communicated through graphics 	<ul style="list-style-type: none"> ◆ effective communication through graphics ◆ effective detail is communicated through graphics 	<ul style="list-style-type: none"> ◆ highly effective communication through graphics ◆ highly effective detail is communicated through graphics

Further information for assessing – 'applying graphic techniques'

- ◆ Candidates must use recognised graphic types that are appropriate for their purpose.
- ◆ Award marks for the appropriate use of graphics, not just the quality of the graphic.
- ◆ Candidates should use graphics to communicate detail where appropriate.
- ◆ To achieve marks in the top band, it is likely that the candidate will have used a range of graphic types that communicate details such as sizes, features of components and assembly.
- ◆ Candidates can use graphics generated for the 'planning for commercial manufacture' as evidence for this section.

Skill: applying modelling techniques

Make your marking judgements based on the candidate's ability to apply a range of appropriate modelling techniques to inform and communicate design decisions.

Skill	Max mark	1-3 marks	4-6 marks	7-8 marks
Applying modelling techniques	8	<ul style="list-style-type: none"> ◆ limited use of modelling to inform design decisions ◆ limited use of modelling to communicate design decisions 	<ul style="list-style-type: none"> ◆ adequate use of modelling to inform design decisions ◆ adequate use of modelling to communicate design decisions 	<ul style="list-style-type: none"> ◆ effective use of modelling to inform design decisions ◆ effective use of modelling to communicate design decisions

Further information for assessing – 'applying modelling techniques'

- ◆ Candidates can carry out modelling at any stage of the design process.
- ◆ To gain marks, candidates must indicate what they have learned from the models and what decisions they have reached.
- ◆ To achieve marks in the top band, it is likely that the candidate will have used a range of modelling techniques.
- ◆ Modelling can be computer-generated and/or physical models.

Skill: demonstrating practical modelling skills

Make your marking judgements based on the candidate's ability to produce detailed and accurate models.

Skill	Max mark	1-3 marks	4-6 marks	7-8 marks
Demonstrating practical modelling skills	8	<ul style="list-style-type: none">◆ limited demonstration of practical skills◆ limited detail and accuracy	<ul style="list-style-type: none">◆ adequate demonstration of practical skills◆ adequate detail and accuracy	<ul style="list-style-type: none">◆ effective demonstration of practical skills◆ effective detail and accuracy

Further information for assessing – 'demonstrating practical modelling skills'

- ◆ In this section, award marks for practical modelling skills. Do not award marks for computer-generated modelling.
- ◆ Although the candidate can demonstrate skills across more than one model, it is possible to gain marks in the top band with a single model.
- ◆ The candidate must demonstrate skills in models that develop or communicate the proposal.

Skill: producing a plan for commercial manufacture

Make your marking judgements based on the candidate's ability to produce a plan that includes details of component parts and assembly of the design proposal.

Skill	Max mark	1-2 marks	3-4 marks	5-6 marks
Producing a plan for commercial manufacture	6	<ul style="list-style-type: none"> ◆ limited detail of component parts ◆ limited detail of assembly ◆ product part table contains limited detail 	<ul style="list-style-type: none"> ◆ adequate detail of component parts ◆ adequate detail of assembly ◆ product part table contains adequate detail 	<ul style="list-style-type: none"> ◆ effective detail of component parts ◆ effective detail of assembly ◆ product part table contains effective detail

Further information for assessing – 'producing a plan for commercial manufacture'

- ◆ The plan should communicate information required for commercial manufacture. It should communicate manufacturing details and key sizes through a completed product part table (part name, materials, processes), graphic(s) and/or model(s).
- ◆ Only award marks for evidence on the 'planning for commercial manufacture' pro forma.

Instructions for candidates

This assessment applies to the assignment for Higher Design and Manufacture. It has 90 marks out of a total of 170 marks for the course assessment.

It assesses the following skills, knowledge and understanding:

Area	Marks
◆ carrying out research into a given brief	5 marks
◆ producing a specification	3 marks
◆ generating initial ideas	8 marks
◆ exploring ideas	12 marks
◆ refining ideas	6 marks
◆ applying knowledge and understanding of materials and assembly processes	10 marks
◆ applying knowledge and understanding of design	12 marks
◆ applying graphic techniques	12 marks
◆ applying modelling techniques	8 marks
◆ demonstrating practical modelling skills	8 marks
◆ producing a plan for commercial manufacture	6 marks

Your teacher or lecturer will let you know how the assessment will be carried out and any required conditions for doing it.

In this assessment, you have to design a solution in response to a design brief.

You will be given:

- ◆ a choice of three design briefs
- ◆ a 'research' pro forma
- ◆ a 'research and specification' pro forma
- ◆ a 'planning for commercial manufacture' pro forma
- ◆ a 'practical modelling skills' pro forma

Things to remember:

- ◆ You must develop a proposal for one of the design briefs.
- ◆ You must submit your work on a maximum of 12 A3 sheets (or equivalent), including all pro formas. ('research', 'research and specification', 'planning for commercial manufacture' and 'practical modelling skills').
- ◆ You must label each A3 sheet with your name, Scottish Candidate Number and page number, for example page 1 of 12.
- ◆ All the sheets must be single-sided.
- ◆ The work submitted must be your own.

- ◆ There are no restrictions on the resources you can access. You can use books, notes or the internet if you need to.
- ◆ You need to produce suitable evidence for the skills being assessed. The following table provides guidance to help you generate appropriate evidence.

Skill	What you have to do	Notes
Carrying out research into a given design brief	Carry out research into a range of issues appropriate to the brief, using appropriate research techniques	<p>This section is worth 5 marks.</p> <ul style="list-style-type: none"> ◆ You must record your evidence for this skill on the ‘research’ and ‘research and specification’ pro formas. ◆ Your research must be relevant to your chosen brief. ◆ Your research must produce information that can be included in the specification. ◆ You should research issues given within the brief, and any others you identify as important for your task. These can include answering questions on: <ul style="list-style-type: none"> — Aesthetics: Do the aesthetics have to match other products? Do they have to match a location? Does the target market have any preferences? Does the client have any preferences? — Function: What does your proposal have to do? Who is going to use it? Are there any size restrictions? — Ergonomics: What are the key ergonomic issues? Who is going to use your proposal? What are the key sizes? — Performance: How long is your proposal expected to last? What conditions will it be used in? — Cost: How much is the target market willing to pay? How much is the client willing to pay? What are the costs? ◆ You must generate evidence using primary and secondary research methods. The methods you use must allow you to generate valid evidence. ◆ Your research evidence can be sketches, notes, text, graphs or pictures.
Producing a specification	Complete the specification using the information gained from your research	<p>This section is worth 3 marks.</p> <ul style="list-style-type: none"> ◆ You must add your specification points to the ‘research and specification’ pro forma. ◆ Your specification should cover a range of issues. ◆ Your specification should include enough detail to help you develop a proposal.

Skill	What you have to do	Notes
Generating initial ideas	Generate a range of creative and diverse ideas	<p>This section is worth 8 marks.</p> <ul style="list-style-type: none"> ◆ Your ideas should: <ul style="list-style-type: none"> — show creativity — show diversity — address the brief — have enough detail to communicate that they address the brief ◆ You may use idea-generation techniques. ◆ You should aim to generate a large number of ideas quickly – your sketches or models may be rough at this stage. ◆ Your evidence for this skill may be in the form of annotated sketches, drawings, or photographs of models.
Exploring ideas	Carry out exploration of your ideas	<p>This section is worth 12 marks.</p> <ul style="list-style-type: none"> ◆ Your exploration should consider a wide range of alternatives. ◆ You should use the specification to help you explore. ◆ Your exploration should aim to consider alternatives for a range of features. ◆ Your exploration should significantly advance your initial idea, not make simple superficial changes. ◆ You can display your exploration through graphics, models and annotations.
Refining ideas	Carry out refinement of your ideas	<p>This section is worth 6 marks.</p> <ul style="list-style-type: none"> ◆ Your refinement should aim to produce a detailed proposal suitable for manufacture. ◆ You should refine a range of features of the proposal, such as function, sizes, materials, aesthetics and assembly.

Skill	What you have to do	Notes
Applying knowledge and understanding of materials and assembly processes	Apply your knowledge and understanding of materials and assembly processes to develop a proposal	<p>This section is worth 10 marks.</p> <ul style="list-style-type: none"> ◆ You must use your knowledge and understanding to help you develop the proposal. You will not receive marks for simply listing facts. ◆ You should apply the detailed knowledge you have gained in the course. ◆ You can display your knowledge and understanding through your sketches, drawings and models, and clarify them through your written comments. ◆ You should demonstrate that you have made valid decisions based on your knowledge.
Applying knowledge and understanding of design	Apply your knowledge and understanding of design to develop a proposal	<p>This section is worth 12 marks.</p> <ul style="list-style-type: none"> ◆ You must use your knowledge to help you develop the proposal. You will not receive marks for simply listing facts. ◆ You should apply the detailed knowledge you have gained in the course. ◆ You can display your knowledge and understanding through your sketches, drawings and models, and clarify them through your written comments. ◆ You should demonstrate that you have made valid decisions based on your knowledge.
Applying graphic techniques	Use graphics to communicate your proposal and its development	<p>This section is worth 12 marks.</p> <ul style="list-style-type: none"> ◆ Your evidence for this skill can be sketches, drawings and computer graphics throughout your folio. ◆ You should use a range of graphic types that suit their purpose. ◆ You should use graphics to communicate detail where appropriate. ◆ You can use manual and computer graphics as appropriate.

Skill	What you have to do	Notes
Applying modelling techniques	Use models to inform and communicate your decisions	<p>This section is worth 8 marks.</p> <ul style="list-style-type: none"> ◆ The evidence for this skill will be annotated photographs of the model(s). ◆ You must consider the purpose of model(s) before you make them. You will not receive marks for simply making models. ◆ You must clearly communicate any information gained from the model(s). ◆ You can use physical and computer-generated models as appropriate. ◆ Some of the models produced should allow you to demonstrate your practical modelling skills.
Demonstrating practical modelling skills	Use practical modelling skills in developing your proposal	<p>This section is worth 8 marks.</p> <ul style="list-style-type: none"> ◆ The evidence for this skill will be demonstrated through practical models. You will not receive any marks in this section for computer models. ◆ You should demonstrate your skills through models that develop or communicate your proposal ie your skills may be demonstrated in models which are used at any stage of your assignment, for example: <ul style="list-style-type: none"> — exploring or refining your proposal — communicating your proposal — use of standard components. ◆ The evidence for this must be photographs, which must be on the ‘practical modelling skills’ pro forma. ◆ The photographs must be clear enough to show your skills. ◆ You should demonstrate detail and accuracy in some of your models. ◆ You should give an indication of the sizes of your models. You may do this by adding dimensions or including a ruler in your photographs.

Skill	What you have to do	Notes
Producing a plan for commercial manufacture	Produce a plan which details the commercial manufacture for your proposal	<p>This section is worth 6 marks.</p> <ul style="list-style-type: none"> ◆ The evidence for this will be in the form of sketches, drawings and text which must be on the 'plan for commercial manufacture' pro forma. ◆ Your plan should include: <ul style="list-style-type: none"> — detail of component parts – this may be in the form of dimensioned drawings, sketches or photographs of models — details of assembly — a completed product part table

Design briefs

You must use one of the following briefs as a basis for your Higher Design and Manufacture assignment.

Problem situation

The American Streetfood company is opening themed food courts at various locations across Scotland.

The company has identified three products that they require for their food courts. The three products are described in the briefs on the following pages.

The company has established the basic requirements for each product, and detailed these in the design briefs. You can find these on the following pages.

The company wants you to develop a proposal for one of the products.

You should carry out research to gather additional information and complete the specification.

Design brief 1

The American Streetfood company would like a design proposal for a dessert topping station in the food court, for customers to collect different toppings for their hot and cold desserts.

The proposal needs to hold a range of dessert toppings and other items such as napkins. These should be held and dispensed in a variety of ways and should be accessible by both adults and children.

The company would like the proposal to be inspired by the theme 'American Sweet Treats' and it should be easy for employees to clean and restock.

You can use one or more of the components shown on pages 28-31 in the assembly of the proposal.

You must gather additional information through appropriate research, and complete a detailed specification.

Design brief 2

The American Streetfood company would like a design proposal for children's seating at the food court.

The proposal needs to accommodate more than one child, include an element of play and be able to securely hold their food and drink items.

The company would like the proposal to be inspired by the theme 'Children's Fun Snacks'.

You can use one or more of the components shown on pages 28-31 in the assembly of the proposal.

You must gather additional information through appropriate research, and complete a detailed specification.

Design brief 3

The American Streetfood company would like a design proposal for a product that will provide a dog, or dogs, with shelter and refreshments while their owners are at the food court.

The product needs to incorporate a standard water bowl and provide an activity for the dog(s) to dispense treats. The product should include a feature to secure the dog(s).

The company would like the proposal to be inspired by the theme 'American Street Food'.

You can use one or more of the components shown on pages 28-31 in the assembly of the proposal.

You must gather additional information through appropriate research, and complete a detailed specification.

COMPONENT A – 2 sizes available: (sizes can be adjusted to suit your design)

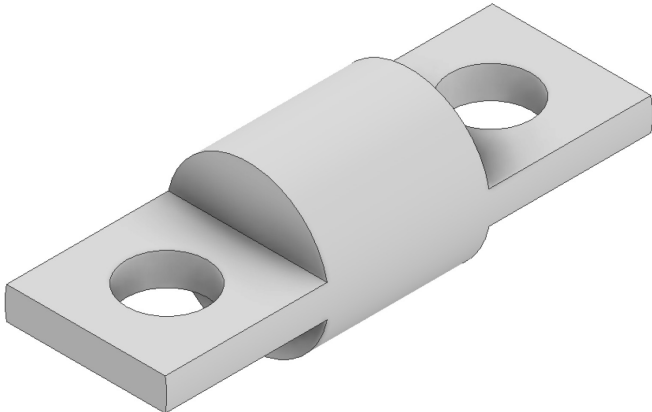

Mild steel – All sizes in mm

SMALL COMPONENT

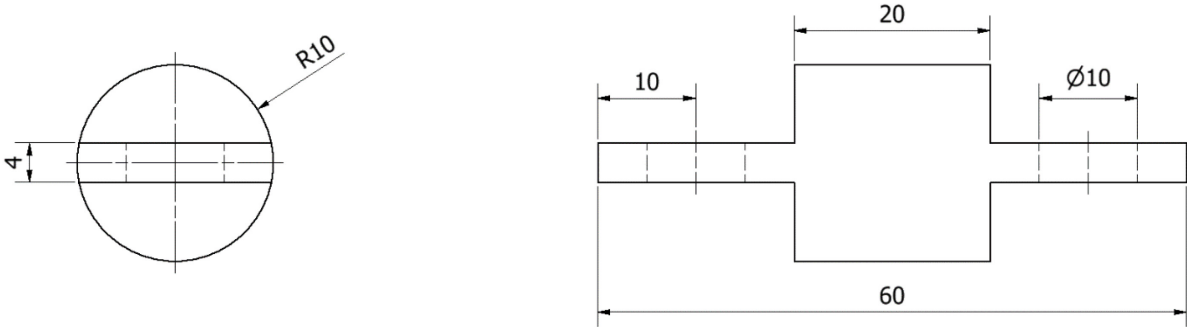

LARGE COMPONENT

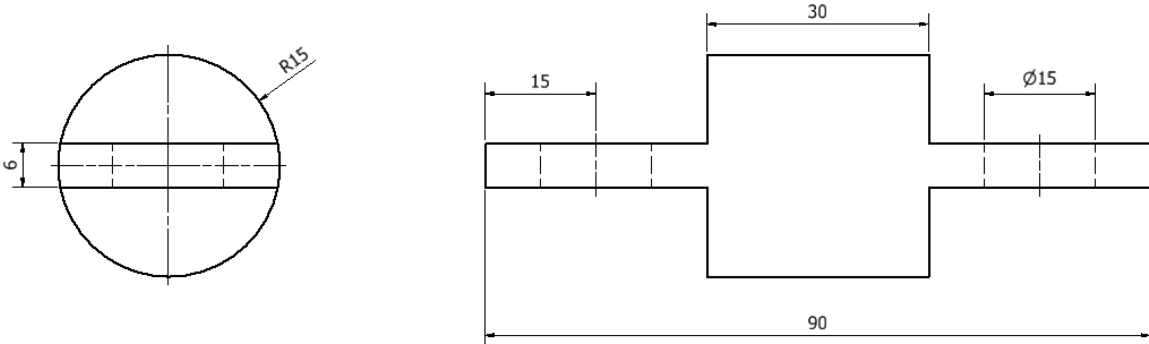

COMPONENT B – 2 sizes available: (sizes can be adjusted to suit your design)

Stainless Steel - ALL SIZES IN MM

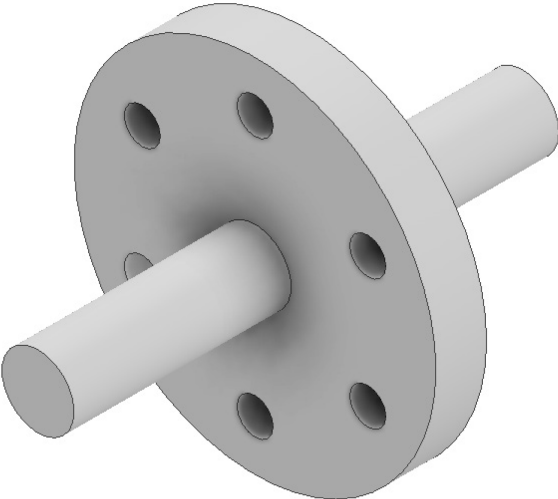

SMALL COMPONENT

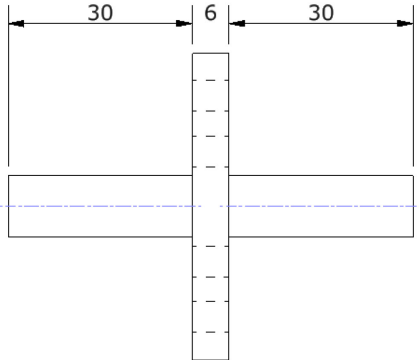
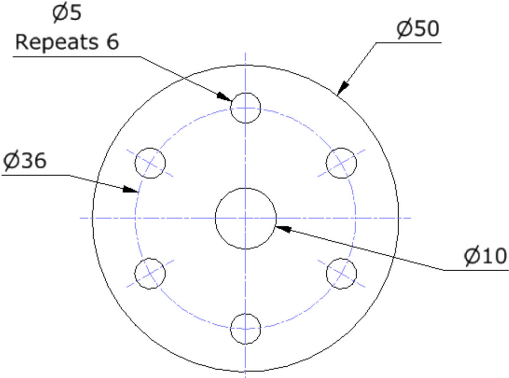

LARGE COMPONENT

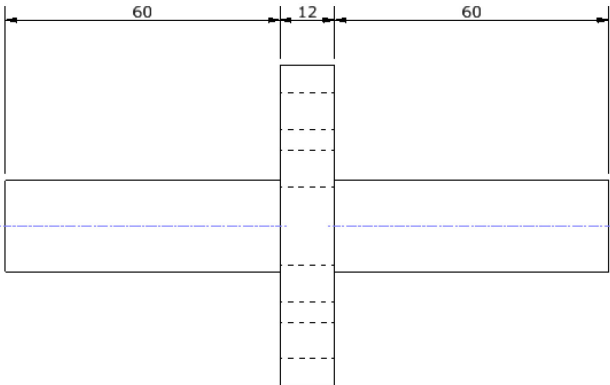
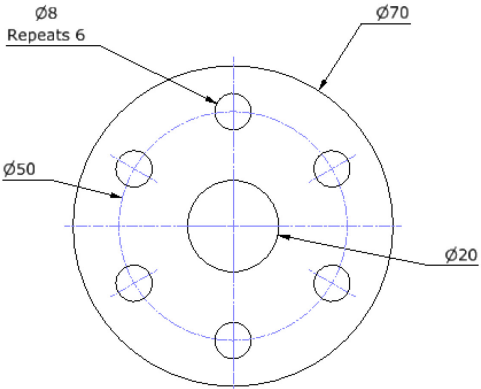

COMPONENT C – 2 sizes available: (sizes can be adjusted to suit your design)

Aluminium - ALL SIZES IN MM

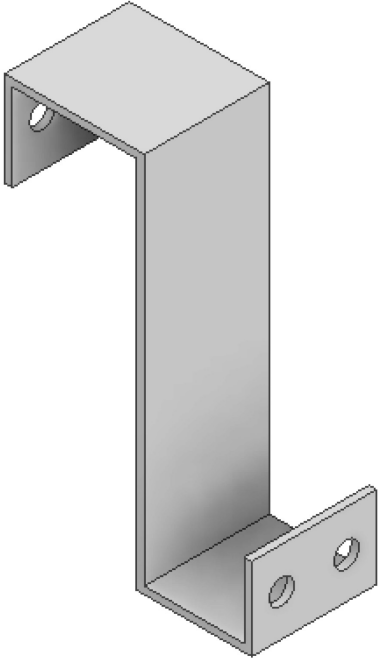

SMALL COMPONENT

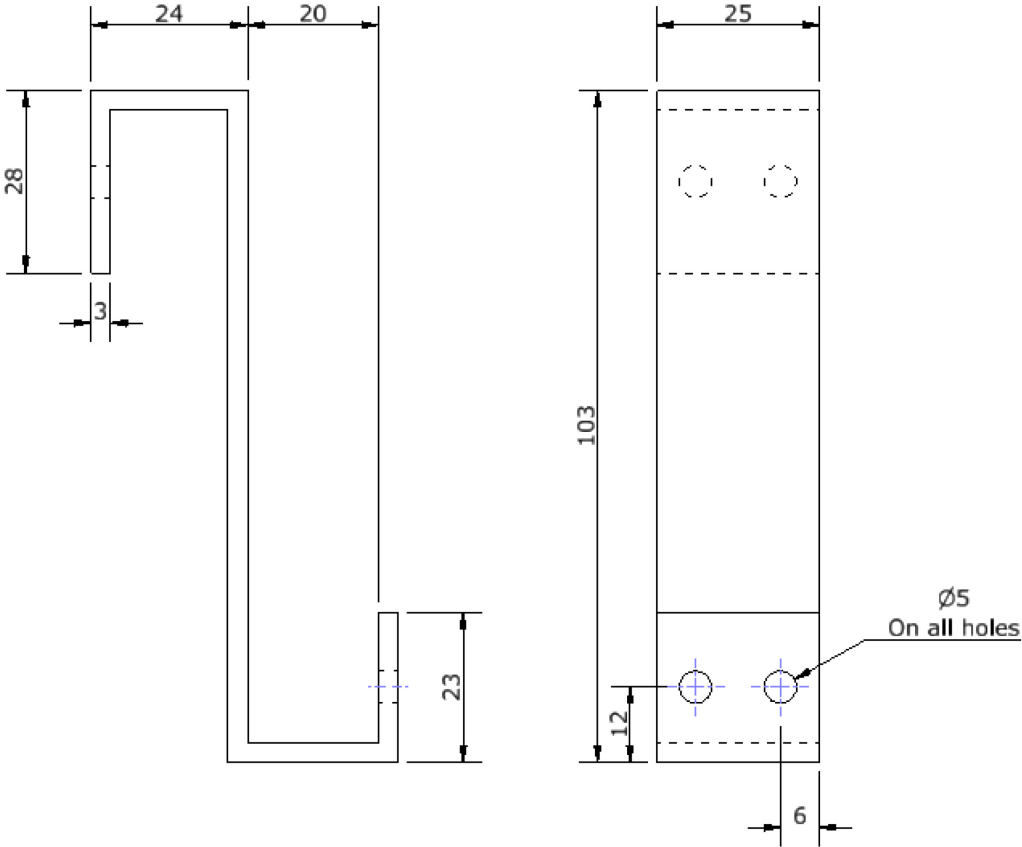

LARGE COMPONENT

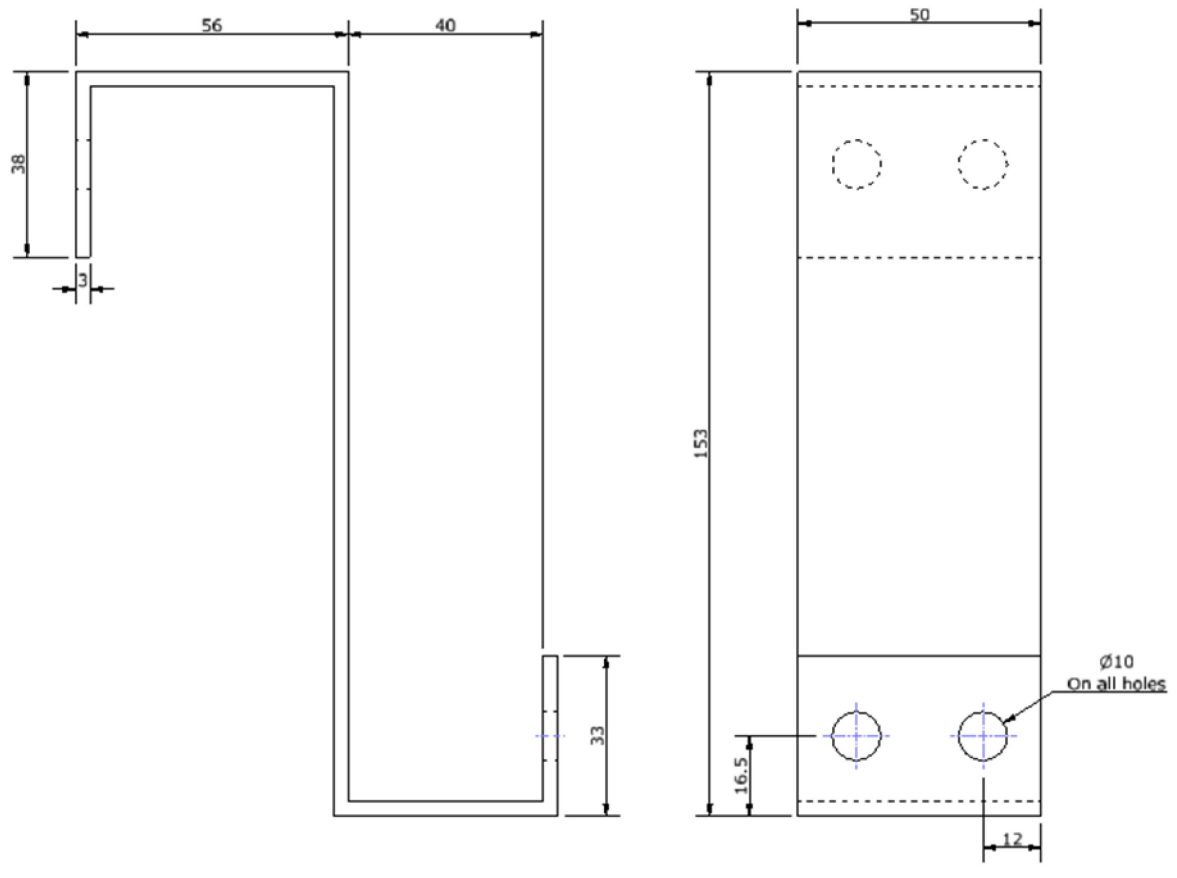

Administrative information

Published: November 2024 (version 1.0)

History of changes

Version	Description of change	Date

Security and confidentiality

This document can be used by SQA approved centres for the assessment of National Courses and not for any other purpose.

This document may only be downloaded from SQA's designated secure website by authorised personnel.

© Scottish Qualifications Authority 2024