



National
Qualifications
2022 MODIFIED

X835/77/11

**Graphic Communication
Supplementary sheets**

MONDAY, 16 MAY

1:15 PM – 3:15 PM

Supplementary sheets 1 and 2 for use with question 2, supplementary sheet 3 for use with question 3, and supplementary sheet 4 for use with question 7.



* X 8 3 5 7 7 1 1 *

Supplementary sheet 1 for use with question 2 (a)

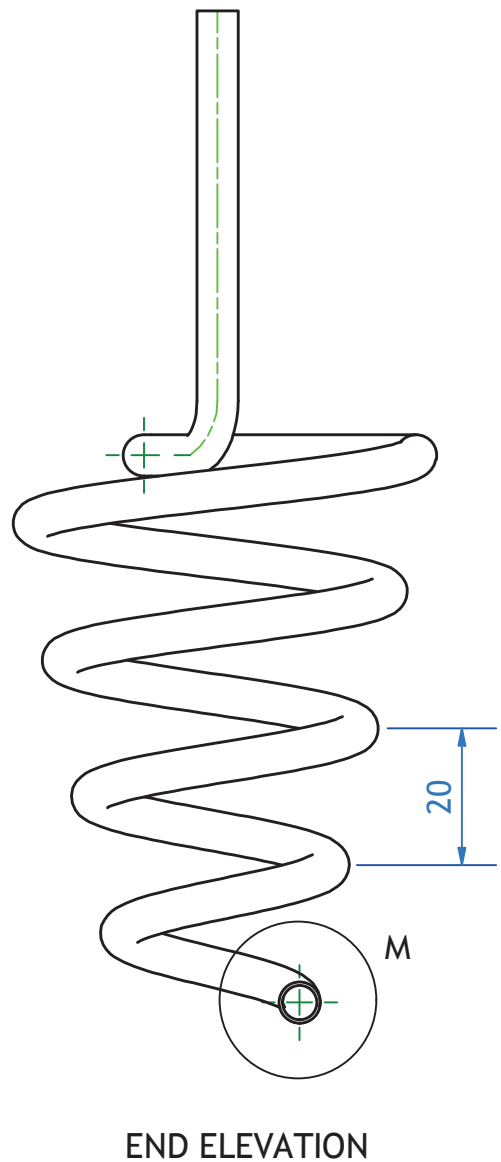
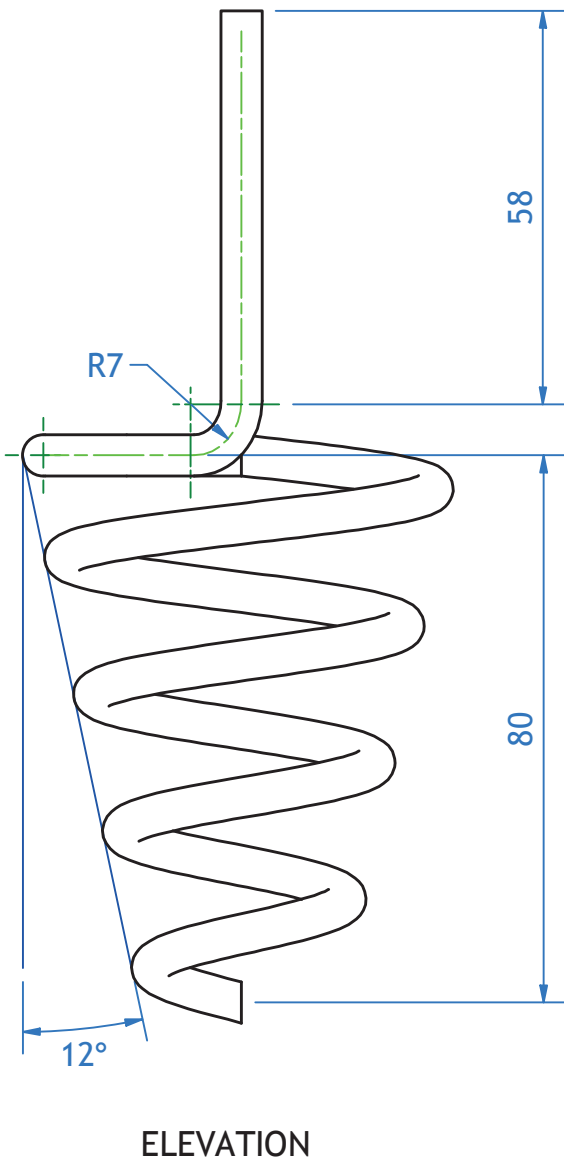
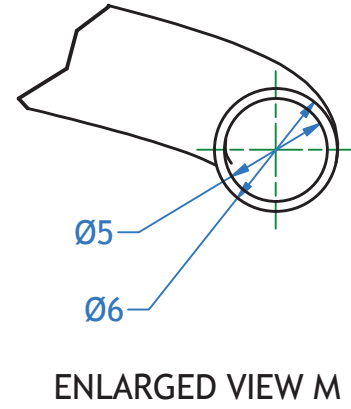
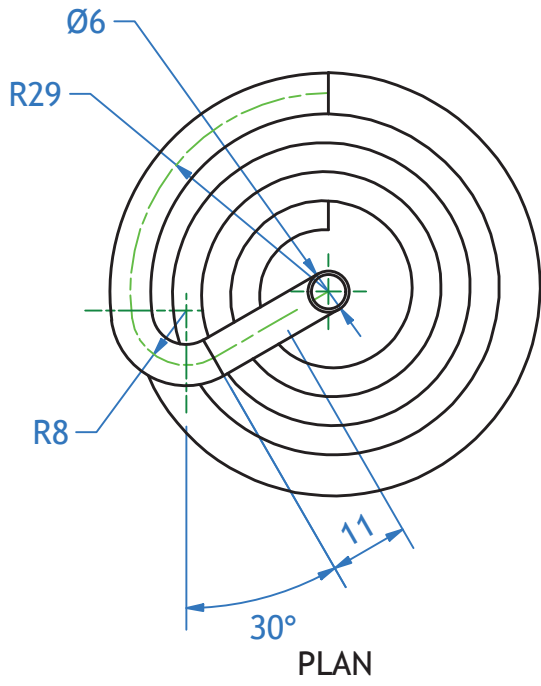

SOME CENTRE LINES AND
HIDDEN DETAIL HAVE BEEN
REMOVED FOR CLARITY

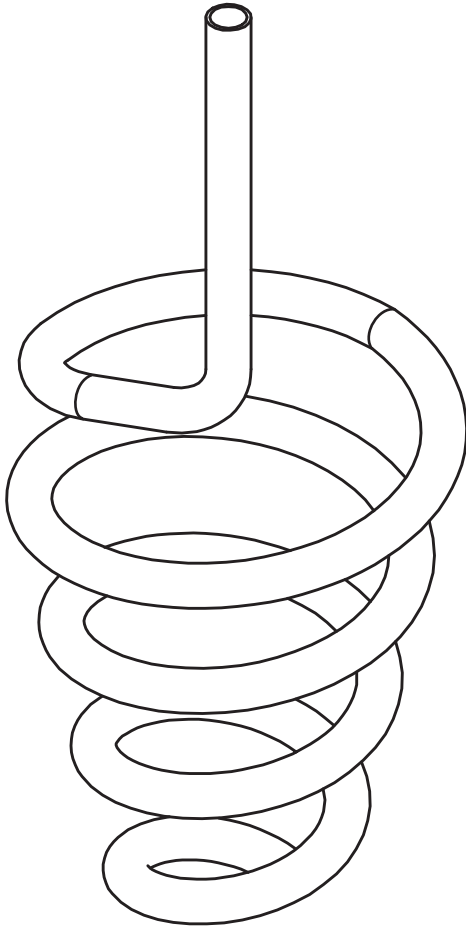

ISOMETRIC

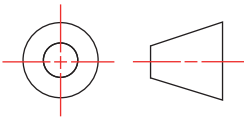
TITLE: STRAW	AUTHOR: A.NON	
DRAWING NUMBER 1		
MATERIAL: POLYPROPYLENE		SCALE: 1:1
ALL DIMENSIONS IN MM TOLERANCE ± 0.2 UNLESS OTHERWISE STATED		DATE: 10/10/21

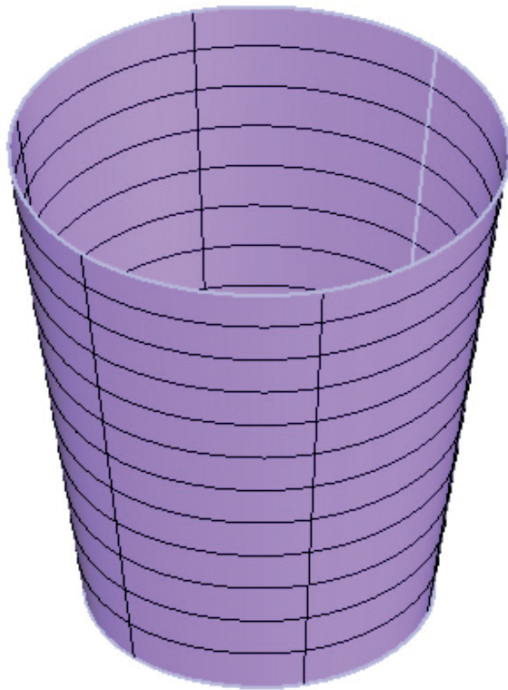

STAGE 1

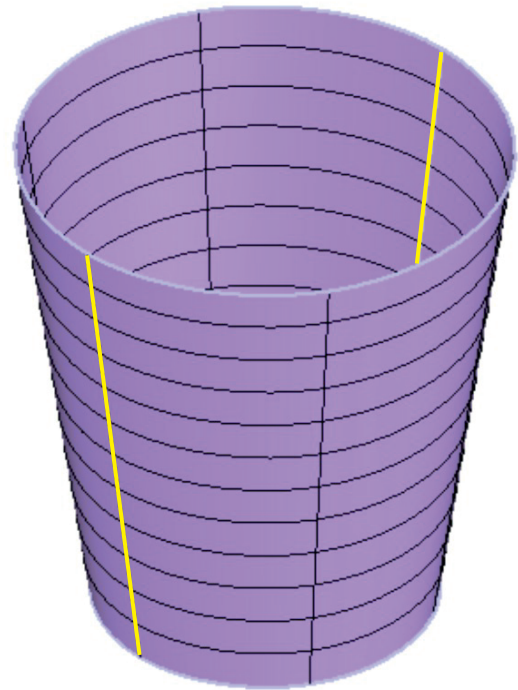

STAGE 2

TITLE: CONTAINER	AUTHOR: A.NON	
DRAWING NUMBER 1		
MATERIAL: POLYPROPYLENE		SCALE: 1:1
ALL DIMENSIONS IN MM TOLERANCE ± 0.2 UNLESS OTHERWISE STATED		DATE: 10/10/21

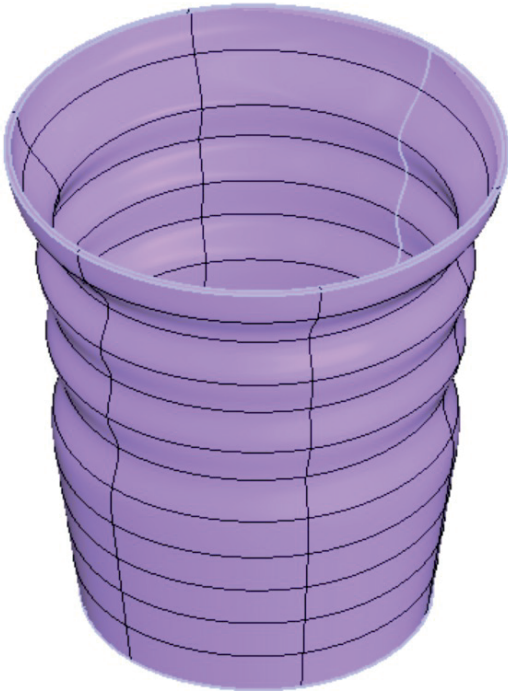

STAGE 3



STAGE 4

TITLE: CONTAINER	AUTHOR: A.NON	
DRAWING NUMBER 2		
MATERIAL: POLYPROPYLENE		SCALE: 1:1
ALL DIMENSIONS IN MM TOLERANCE ± 0.2 UNLESS OTHERWISE STATED		DATE: 10/10/21

The artwork guidelines below help customers plan out their designs.

Artwork Guidelines

Free Design Service

- You can submit your layout and colours on a sketch but if you use our template the process is much faster.
- The template is available from www.thecyclejersey_template.
- Artwork should be placed inside the dotted lines. Please note the long sleeve and short sleeve options.

Jersey Details

- Stretchable fabric.
- Breathable fabric.
- Waterproof coating.
- Hidden comfort stitching.
- Double stitching for joint strength.

No limit to number of colours

- Please submit CMYK colour codes if possible. We also accept Pantone and RGB. If you supply RGB we will convert this for print.
- If there is any doubt in the colours, when we are testing the print, we will print a mini colour chart along with your colour sample to allow you to choose the desired colour.

Logos

- Logos should be supplied in print ready format (ai, eps, svg or pdf).
- jpg, png or tiff files can be used also but they must be at least 150dpi at actual size.
- Convert ALL fonts to outlines / curves. jpg and png images must be min 150dpi.

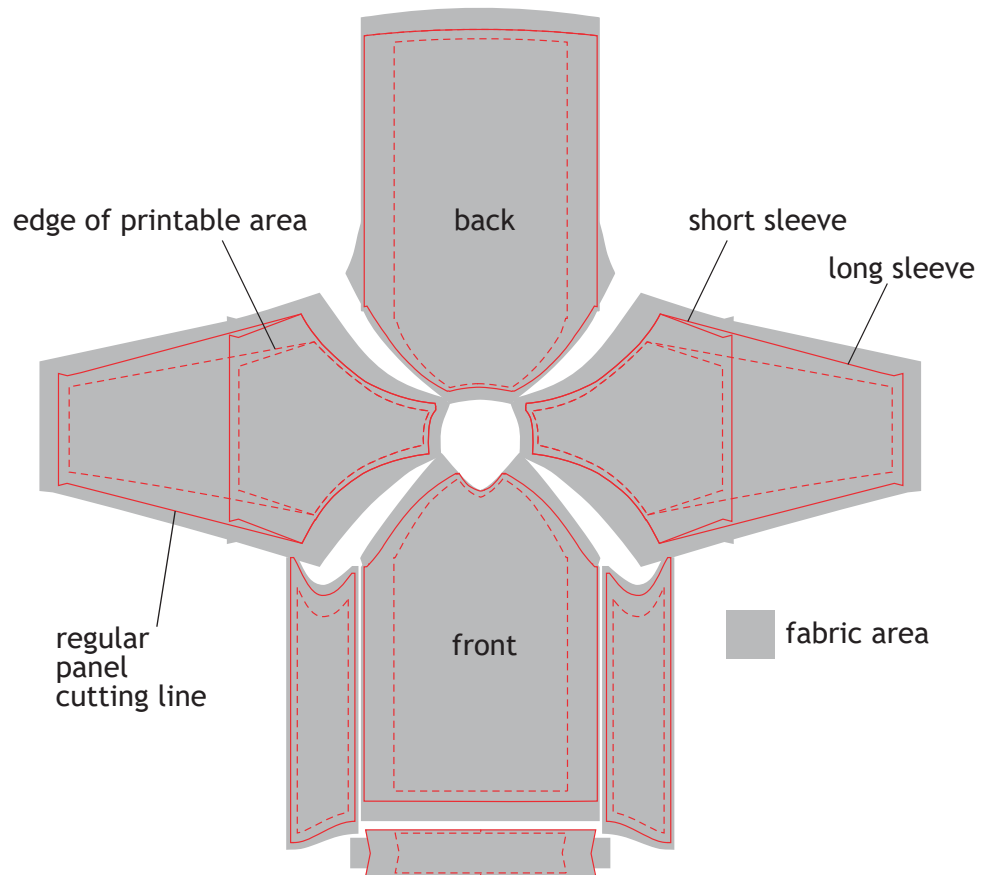

Cycle Jersey Template .dxf

[Turn over for next supplementary sheet

DO NOT WRITE ON THIS PAGE

KAYAK BODY

WALL THICKNESS 5 mm

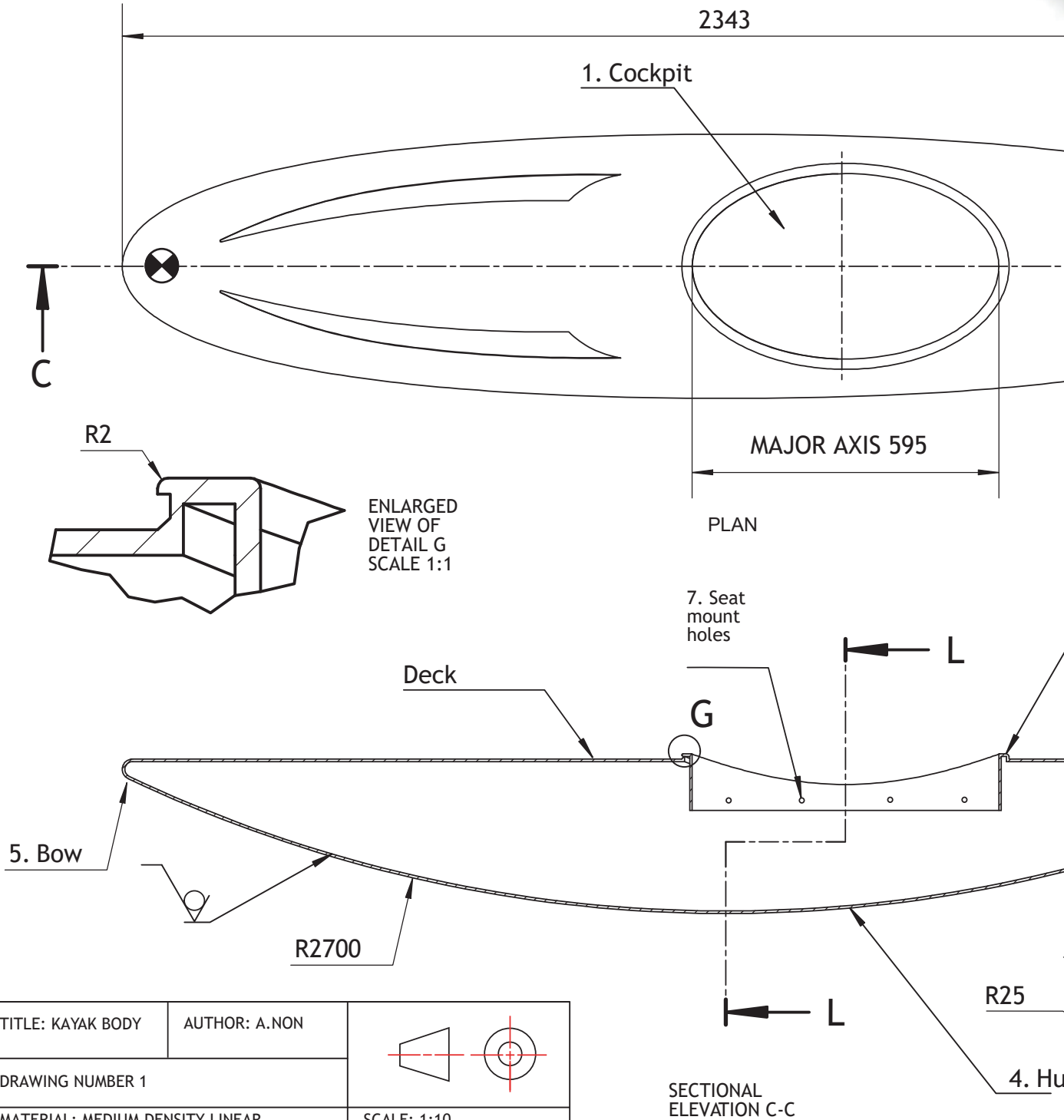

TITLE: KAYAK BODY	AUTHOR: A.NON	
DRAWING NUMBER 1		
MATERIAL: MEDIUM DENSITY LINEAR POLYETHYLENE		SCALE: 1:10
ALL DIMENSIONS IN MM TOLERANCE ± 0.05 UNLESS OTHERWISE STATED		DATE: 10/10/21

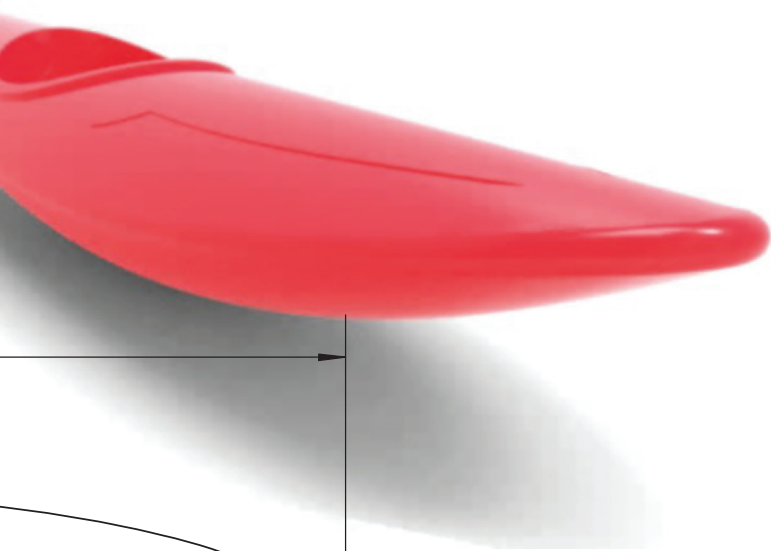

NAMED FEATURES
1. Cockpit
2. Cockpit coaming
3. Rope attachment point
4. Hull
5. Bow
6. Stern
7. Seat mount holes

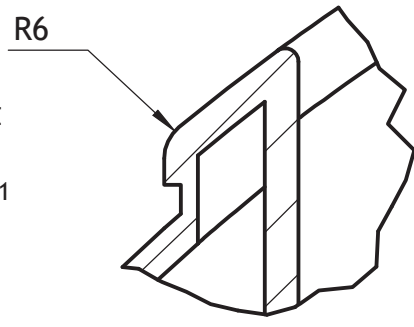
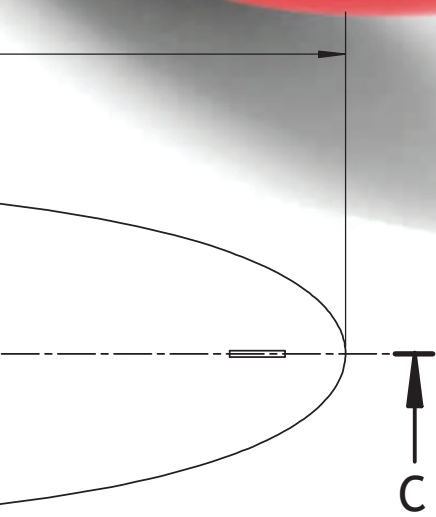

ENLARGE VIEW OF AREA M SCALE 1:1

2. Cockpit coaming. Note: change of radius around internal edge.

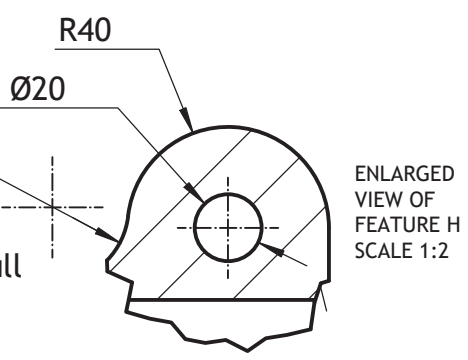
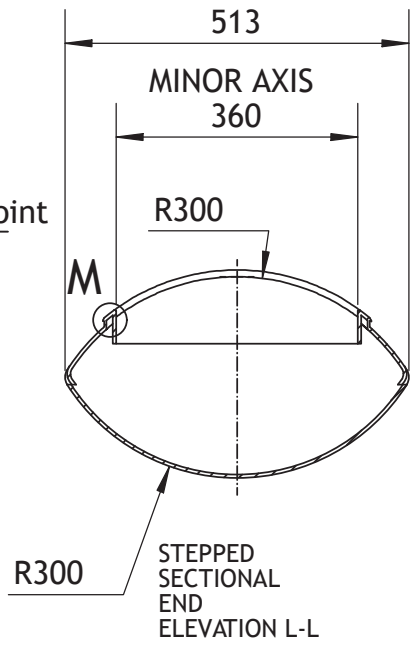
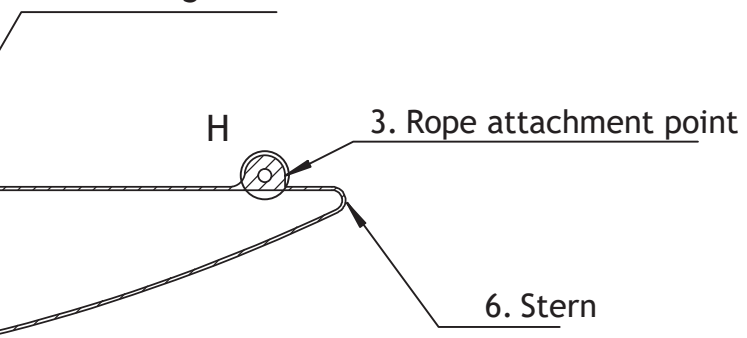

ENLARGED VIEW OF FEATURE H SCALE 1:2

A NUMBER OF CENTRE-LINES HAVE BEEN REMOVED FOR CLARITY
SOME LINE THICKNESSES HAVE BEEN CHANGED FOR CLARITY

[BLANK PAGE]

DO NOT WRITE ON THIS PAGE

[BLANK PAGE]

DO NOT WRITE ON THIS PAGE

[BLANK PAGE]

DO NOT WRITE ON THIS PAGE