

The logo consists of the letters 'N5' in a large, bold, white font, set against a solid purple square background.

National 5  
Coursework  
Assessment Task



---

# National 5 Engineering Science Assignment Finalised Marking instructions

© Scottish Qualifications Authority 2025

These marking instructions have been prepared by examination teams for use by SQA appointed markers when marking external course assessments.

The information in this document may be reproduced in support of SQA qualifications only on a non-commercial basis. If it is reproduced, SQA must be clearly acknowledged as the source. If it is to be reproduced for any other purpose, written permission must be obtained from [permissions@sqa.org.uk](mailto:permissions@sqa.org.uk).

## General marking principles

This information is provided to help you understand the general principles that must be applied when marking candidate responses in this assignment. These principles must be read in conjunction with the detailed/specific marking instructions, which identify the key features required in candidate responses.

- a Marks for each candidate response must always be assigned in line with these general marking principles and the specific marking instructions for this assessment.
- b Marking should always be positive. This means that, for each candidate response, marks are accumulated for the demonstration of relevant skills, knowledge and understanding: they are not deducted from a maximum on the basis of errors or omissions.
- c If a specific candidate response is not covered by either the general marking principles or detailed marking instructions, you must seek guidance from your team leader.

## Detailed marking instructions

Task			Expected answer(s)	Max mark	Additional guidance
1	a	i	 <pre> graph LR     A[user input] --&gt; B[pool heating]     B --&gt; C[heat]             </pre>	2	<ul style="list-style-type: none"> <li>• user input/desired temperature/set temperature level identified. (1 mark)</li> <li>• temperature output (implied) identified. (1 mark)</li> </ul> <p>Do not accept input or output components.</p> <p>Ignore extra boxes or words.</p> <p>If no arrows shown assume left to right.</p>

Task			Expected answer(s)	Max mark	Additional guidance
1	a	ii	<pre> graph LR     subgraph SystemBoundary [ ]         direction LR         MC[microcontroller] --&gt; D[driver]         D --&gt; H[heater]         H --&gt; TS[temperature sensor]         TS --&gt; MC     end     UI[user input] --&gt; MC     H -- heat --&gt; Out[ ]   </pre>	6	<ul style="list-style-type: none"> <li>• user input/desired temperature/set temperature, and temperature output (implied). (1 mark) Apply FTE from Task 1a(i).</li> <li>• system boundary around sub-systems only and boxes around each sub-system. (1 mark)</li> <li>• driver connected to microcontroller. (1 mark)</li> <li>• heater in output position. (1 mark)</li> <li>• temperature sensor connected to microcontroller. (1 mark)</li> </ul> <p>Accept thermostat/thermocouple/heat sensor (do not accept thermometer or thermistor).</p> <ul style="list-style-type: none"> <li>• feedback loop from after heater into microcontroller with both arrowheads. (1 mark)</li> </ul> <p>Do not accept action (eg heater on).</p> <p>Ignore additional sub-systems.</p> <p>Ignore boxes around external inputs/outputs.</p> <p>If no arrows shown assume left to right.</p>

Task		Expected answer(s)	Max mark	Additional guidance
1	b	<p style="text-align: center;">input sensing circuit</p>	2	<p>If simulated/constructed. (0 marks)</p> <ul style="list-style-type: none"> <li>• correct symbol for resistor (variable) and thermistor (ignore -t). (1 mark)</li> <li>• correct position and wiring of components to create a cold sensor. (1 mark)</li> </ul> <p>Values of components are not required.</p> <p>Ignore additional circuitry.</p>

Task		Expected answer(s)	Max mark	Additional guidance								
1	c	<table border="1"> <thead> <tr> <th>Planned test</th> <th>Expected result</th> </tr> </thead> <tbody> <tr> <td><b>Test 1</b> Reduce the water temperature.</td> <td><math>V_{out}</math> will increase.</td> </tr> <tr> <td><b>Planned test</b></td> <td><b>Expected result</b></td> </tr> <tr> <td><b>Test 2</b> Increase the water temperature.</td> <td><math>V_{out}</math> will decrease.</td> </tr> </tbody> </table>	Planned test	Expected result	<b>Test 1</b> Reduce the water temperature.	$V_{out}$ will increase.	<b>Planned test</b>	<b>Expected result</b>	<b>Test 2</b> Increase the water temperature.	$V_{out}$ will decrease.	3	<p>Testing results must refer to a cold sensor.</p> <p><b>Test 1</b></p> <ul style="list-style-type: none"> <li>expected result for decreasing temperature level in terms of <math>V_{out}</math> increasing. (1 mark)</li> </ul> <p><b>Test 2</b></p> <ul style="list-style-type: none"> <li>test for increasing temperature level. (1 mark)</li> </ul> <p>Accept a variable resistor test only if statement refers to an increase/decrease of resistance and included in <b>Task 1b</b>.</p> <ul style="list-style-type: none"> <li>expected result for increasing temperature level in terms of <math>V_{out}</math> decreasing. (1 mark)</li> </ul> <p>Apply FTE to expected result in test 2 from test 1 expected result.</p> <p>If no planned test 2 given, then no mark can be awarded for the expected result unless the statement includes a description of the planned test.</p>
Planned test	Expected result											
<b>Test 1</b> Reduce the water temperature.	$V_{out}$ will increase.											
<b>Planned test</b>	<b>Expected result</b>											
<b>Test 2</b> Increase the water temperature.	$V_{out}$ will decrease.											

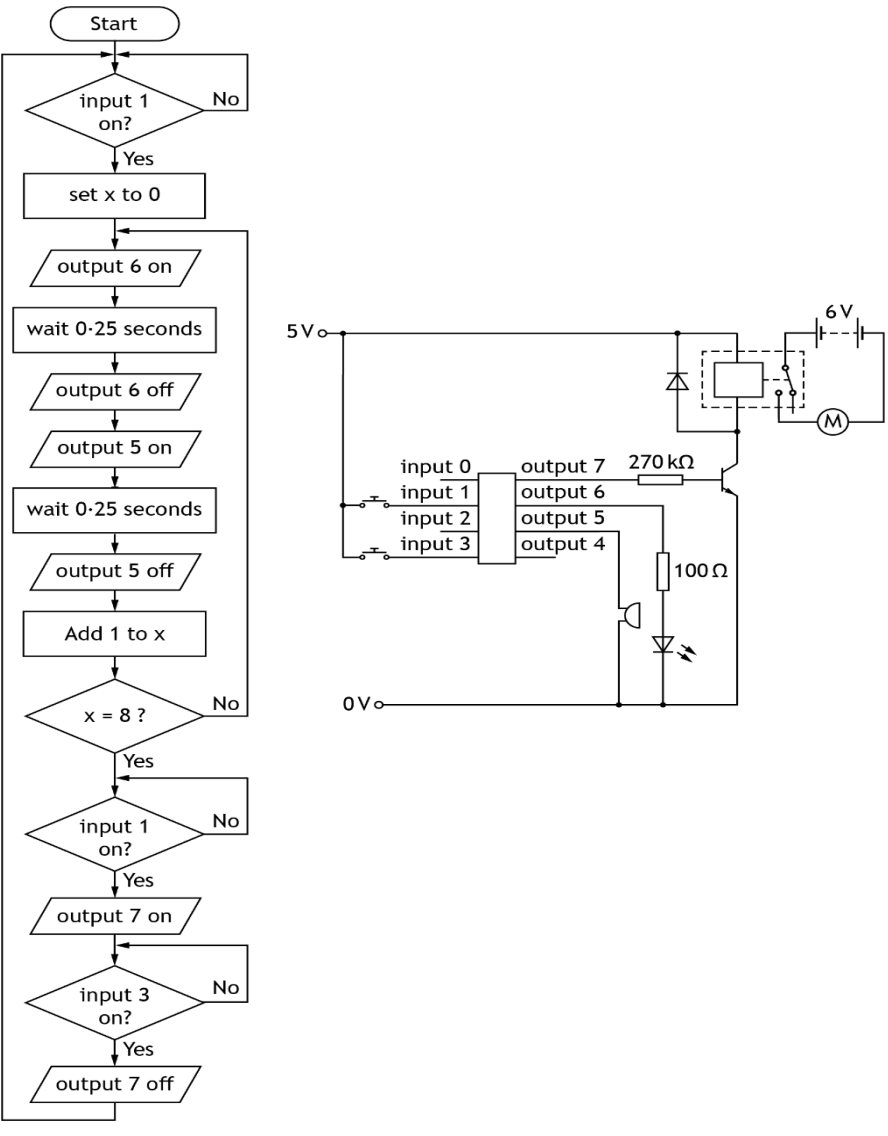
Task		Expected answer(s)	Max mark	Additional guidance
2	a	 <p>The flowchart starts with 'Start', leading to a decision 'input 1 on?'. If 'No', it loops back to the start. If 'Yes', it proceeds to 'set x to 0', then 'output 6 on', 'wait 0.25 seconds', 'output 6 off', 'output 5 on', 'wait 0.25 seconds', 'output 5 off', 'Add 1 to x', and a decision 'x = 8?'. If 'No', it loops back to 'output 6 on'. If 'Yes', it leads to another decision 'input 1 on?'. If 'No', it loops back to 'x = 8?'. If 'Yes', it leads to 'output 7 on', then a decision 'input 3 on?'. If 'No', it loops back to 'input 1 on?'. If 'Yes', it leads to 'output 7 off', which loops back to 'input 1 on?'.</p> <p>The electronic circuit diagram shows a microcontroller with inputs 0, 1, 2, 3 and outputs 4, 5, 6, 7. Input 1 is connected to a switch. Output 6 is connected to a 270 kΩ resistor and a transistor. Output 5 is connected to a 100 Ω resistor and a diode. Output 7 is connected to a motor. A 6V battery and a switch are connected to the motor. The circuit is powered by 5V and 0V.</p>	5	<p><b>Electronic circuit</b></p> <ul style="list-style-type: none"> <li>all correct components selected and wiring attempted. (1 mark)</li> <li>correct wiring, microcontroller pin numbers and connection, component orientations and component values. (1 mark)</li> </ul> <p>If pin numbers are not visible on microcontroller refer to flowchart.</p> <p>Allow use of alternative sized microcontrollers.</p> <p>If electronic circuit constructed allow use of alternative pin numbers appropriate to hardware used.</p> <p><b>Flowchart</b></p> <ul style="list-style-type: none"> <li>correct symbols (to the software) with feedback loops exactly as shown. (1 mark)</li> <li>all correct pin numbers (FTE from circuit), pin states, decisions and time delays. (1 mark)</li> </ul> <p><b>Integration</b></p> <ul style="list-style-type: none"> <li>flowchart and electronic circuit. (1 mark)</li> </ul>

Task		Expected answer(s)			Max mark	Additional guidance
2	b				5	<p>Apply FTE from Task 2a and from each previous response.</p> <p><b>Test 1</b></p> <ul style="list-style-type: none"> <li>description of LED and buzzer and repeating 8 times. (1 mark)</li> <li>description of amendment to flowchart and appropriate re-test result including LED and buzzer and x5. (1 mark)</li> </ul> <p><b>Test 2</b></p> <ul style="list-style-type: none"> <li>description of relay not switching and motor not turning. (1 mark)</li> <li>description of amendment to circuit to allow the transistor to switch and appropriate re-test result including relay and motor. (1 mark)</li> </ul> <p><b>Test 3</b></p> <ul style="list-style-type: none"> <li>description relay switching off and motor stops. (1 mark)</li> </ul> <p>If no evidence of simulation/construction for Task 2a and Task 2c then award 0 marks.</p> <p>If no evidence for Task 2a, then marks should be awarded for planned amendments and re-test results, up to a maximum of two marks, based on the evidence in Task 2c.</p>
		<b>Test 1: Initial test result</b>	<b>Planned amendment to circuit/flowchart</b>	<b>Re-test result</b>		
		<i>When the start switch is pressed ...</i> The warning LED flashes and the buzzer sounds 8 times.	Reduce the number of loops (from 8 to 5 in flowchart).	<i>When the start switch is pressed ...</i> The warning LED flashes and the buzzer sounds 5 times.		
		<b>Test 2: Initial test result</b>	<b>Planned amendment to circuit/flowchart</b>	<b>Re-test result</b>		
		<i>When the start switch is pressed again... the relay does not switch on and the motor does not turn.</i>	Reduce the resistance (of the 270kΩ resistor).	<i>When the start switch is pressed again... the relay switches on and the motor turns.</i>		
<b>Test 3: Initial test result</b>	<b>Planned amendment to circuit/flowchart</b>	<b>Re-test result</b>				
<i>When the stop switch is pressed... the relay switches off and motor slows down to a stop.</i>	No amendment required.	<i>When the stop switch is pressed...no re-test required.</i>				

Task		Expected answer(s)	Max mark	Additional guidance
2	c		2	<p>Take account of simulation/construction evidence from <b>Task 2a</b> and testing evidence from <b>Task 2b</b>. Apply FTE.</p> <p><b>Test 1 amendment</b></p> <ul style="list-style-type: none"> <li>• correction to x5 loop/ proposed amendment. (1 mark)</li> </ul> <p><b>Test 2 amendment</b></p> <ul style="list-style-type: none"> <li>• correction of base resistor value/ proposed amendment. (1 mark)</li> </ul>

Task		Expected answer(s)		Max mark	Additional guidance
2	d	<p><b>Improvement that will benefit the operator</b></p> <p>Replace the push to make switch with a SPST/latched switch.</p> <p>Remove the second flowchart decision box for input 1/start switch.</p> <p>Add a sensor at the bottom of the flume.</p>	<p>The operator does not have to keep pressing the switch.</p> <p>This will save the operator time/no need to press the switch twice.</p> <p>The signal could be used to indicate to the operator when a swimmer has exited the flume/when it is safe to send the next swimmer down.</p>	2	<p>Descriptive response relating to the operator.</p> <ul style="list-style-type: none"> <li>• appropriate improvement to the flume control for the operator. (1 mark)</li> <li>• appropriate justification of suggested improvement. (1 mark)</li> </ul> <p>Apply FTE for justification from suggested improvement.</p>

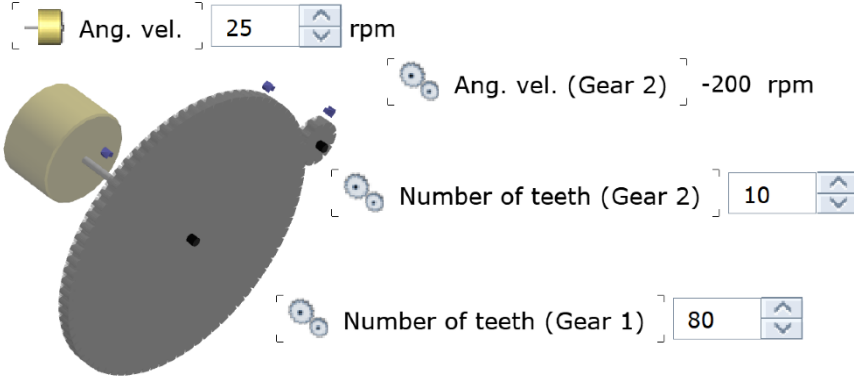
Task		Expected answer(s)	Max mark	Additional guidance
3	a	 <p>Ang. vel. 25 rpm</p> <p>Ang. vel. (Gear 2) -200 rpm</p> <p>Number of teeth (Gear 2) 10</p> <p>Number of teeth (Gear 1) 80</p>	2	<ul style="list-style-type: none"> <li>simple gear train with two gears simulated or constructed, with motor/input identified. (1 mark)</li> <li>gear sizes must be 80 teeth (input) and 10 teeth (output). (1 mark)</li> </ul> <p>Accept hand written values.</p>

Task		Expected answer(s)			Max mark	Additional guidance							
3	b	<table border="1"> <thead> <tr> <th>Planned test 1</th> <th>Input direction</th> <th>Output direction</th> </tr> </thead> <tbody> <tr> <td>Observe and record the direction of the input and output gears.</td> <td>Anti-clockwise</td> <td>Clockwise</td> </tr> </tbody> </table>	Planned test 1	Input direction	Output direction	Observe and record the direction of the input and output gears.	Anti-clockwise	Clockwise				3	<p>Apply FTE from Task 3a.</p> <p>No evidence of simulation/construction in Task 3a then only actual VR calculation can be awarded a mark.</p> <p><b>Planned test 1</b></p> <ul style="list-style-type: none"> <li>directions must be opposite. (1 mark)</li> </ul> <p><b>Planned test 2</b></p> <ul style="list-style-type: none"> <li>correct input and output speeds/turns shown from number of teeth in Task 3a. (1 mark)</li> </ul> <p>Unit not required.</p> <ul style="list-style-type: none"> <li>correct velocity ratio for input and output speeds given in table. (1 mark)</li> </ul>
		Planned test 1	Input direction	Output direction									
Observe and record the direction of the input and output gears.	Anti-clockwise	Clockwise											
<table border="1"> <thead> <tr> <th>Planned test 2</th> <th>Input speed/turns</th> <th>Output speed/turns</th> <th>Actual velocity ratio</th> </tr> </thead> <tbody> <tr> <td>Measure the input speed (or number of turns) and output speed (or number of turns) of the gear system and calculate the actual velocity ratio.</td> <td>25 revs min<sup>-1</sup> or 25 turns</td> <td>200 revs min<sup>-1</sup> or 200 turns</td> <td>1:8  (0.125:1)</td> </tr> </tbody> </table>	Planned test 2	Input speed/turns	Output speed/turns	Actual velocity ratio	Measure the input speed (or number of turns) and output speed (or number of turns) of the gear system and calculate the actual velocity ratio.	25 revs min <sup>-1</sup> or 25 turns	200 revs min <sup>-1</sup> or 200 turns	1:8  (0.125:1)					
Planned test 2	Input speed/turns	Output speed/turns	Actual velocity ratio										
Measure the input speed (or number of turns) and output speed (or number of turns) of the gear system and calculate the actual velocity ratio.	25 revs min <sup>-1</sup> or 25 turns	200 revs min <sup>-1</sup> or 200 turns	1:8  (0.125:1)										

Task		Expected answer(s)			Max mark	Additional guidance
3	c				2	Apply FTE from Task 3b.  <ul style="list-style-type: none"> <li>states that specification (i) was not met <b>and</b> refers to direction of rotation of input <b>and</b> output gears. (1 mark)</li> <li>states that specification (ii) was <b>not</b> met <b>and</b> refers to increase in output speed or incorrect velocity ratio. (1 mark)</li> </ul>
		Specification point	Met? Yes/No	Justification		
		i.	No	The input gear and output gear turn in different directions.		
ii.	No	The speed of the output gear was increased.  Velocity ratio was actually 1:8.				

Task		Expected answer(s)	Max mark	Additional guidance
3	d	<p>The diagram shows a compound gear train. It consists of two shafts. The top shaft has an input gear with 10 teeth and a meshing gear with 50 teeth. The bottom shaft has a meshing gear with 10 teeth and an output gear with 50 teeth. The gears on the top shaft are meshed together, and the gears on the bottom shaft are meshed together. The gears on the top shaft are meshed with the gears on the bottom shaft.</p>	2	<p>If simulated/constructed. (0 marks)</p> <ul style="list-style-type: none"> <li>compound gear train. (1 mark)</li> <li>input labelled, and correct gear sizes to give a speed reduction of 20-30 inclusive. (1 mark)</li> </ul> <p>Accept calculation as evidence of input and gear sizes.</p>

Task		Expected answer(s)	Max mark	Additional guidance
4	a		3	<p>If simulated/constructed. (0 marks)</p> <ul style="list-style-type: none"> <li>NOT gate connected to D. (1 mark)</li> <li>AND gate connected to S and <math>\bar{D}</math>. Apply FTE. (1 mark)</li> <li>OR gate connected to M and <math>S \cdot \bar{D}</math> and connected to P. Apply FTE. (1 mark)</li> </ul>
	b		1	<p>Apply FTE from Task 4a.</p> <ul style="list-style-type: none"> <li>simulate or construct with correctly connected inputs to allow for testing. (1 mark)</li> </ul> <p>Assume inputs are labelled S D M from top to bottom unless simulation/construction is different from the design in Task 4a.</p>

Task		Expected answer(s)				Max mark	Additional guidance
4	c		S	D	M	P	1 If no evidence of simulation/construction in Task 4b then award 0 marks. <ul style="list-style-type: none"> <li>correct results for column P from simulation or construction in Task 4b. Apply FTE. (1 mark)</li> </ul>
			0	0	0	0	
			0	0	1	1	
			0	1	0	0	
			0	1	1	1	
			1	0	0	1	
			1	0	1	1	
			1	1	0	0	
			1	1	1	1	

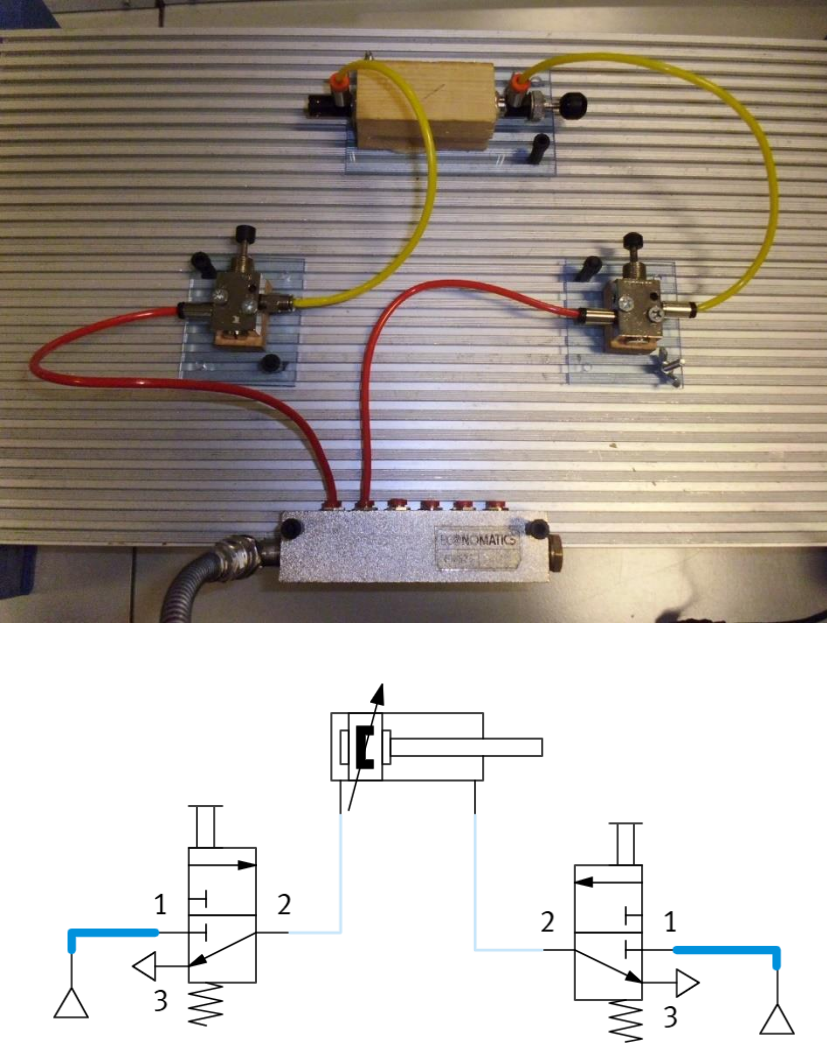
Task		Expected answer(s)	Max mark	Additional guidance
5	a		2	<p>Simulation/construction evidence showing:</p> <ul style="list-style-type: none"> <li>• piping of 3/2 valve with main air to outstroke the piston of the double-acting cylinder. (1 mark)</li> <li>• piping of 3/2 valve with main air to instroke the piston of the double-acting cylinder. (1 mark)</li> </ul> <p>Accept use of any 3/2 valve actuator.</p>

Task		Expected answer(s)	Max mark	Additional guidance
5	b		5	<p>Block diagram, circuit diagram (or a hybrid) Accept constructed/simulated.</p> <ul style="list-style-type: none"> <li>double-acting cylinder with two connections to 5/2 valve (with direction of outstroke indicated, if required). <b>(1 mark)</b></li> <li>unidirectional restrictor to slow outstroke of cylinder on exhaust. <b>(1 mark)</b></li> </ul> <p>Accept restriction on 5/2 exhaust port.</p> <ul style="list-style-type: none"> <li>reservoir (unidirectional restrictor) before piston outstrokes (between 3/2 and 5/2). <b>(1 mark)</b></li> <li>2 x 3/2 valve to cause outstroke and instroke piped to 5/2 valve. <b>(1 mark)</b></li> <li>solenoid actuator on the outstroking 3/2 valve and push button/lever actuator on the instroking 3/2 valve. <b>(1 mark)</b></li> </ul> <p>Components identified or implied (eg UDR) by name or symbols.</p> <p>Connections between components and valves must be shown. Ignore line types. Port to port piping is not required.</p>

Task		Expected answer(s)	Max mark	Additional guidance				
5	c	<table border="1"> <tr> <td style="background-color: #cccccc;"><b>Modification</b></td> <td> <p>Slow the lowering of the pool floor/by adding another unidirectional restrictor.</p> <p>Remove the use of electricity from the pneumatic circuit actuators/use a push button actuator instead of a solenoid actuator.</p> <p>Change the push button to a solenoid (to enable programmable control).</p> <p>Add another 3/2 valve creating AND control.</p> </td> </tr> <tr> <td style="background-color: #cccccc;"><b>Justification</b></td> <td> <p>To ensure the pool will not deepen too quickly/water will not splash over the side.</p> <p>The electrical actuators are less safe than pneumatic actuators where water is being used.</p> <p>Hands free sensor to control the circuit will be safer as there is no risk of electric shock.</p> <p>This is safer as there is less chance of the pool floor being lowered unexpectedly.</p> </td> </tr> </table>	<b>Modification</b>	<p>Slow the lowering of the pool floor/by adding another unidirectional restrictor.</p> <p>Remove the use of electricity from the pneumatic circuit actuators/use a push button actuator instead of a solenoid actuator.</p> <p>Change the push button to a solenoid (to enable programmable control).</p> <p>Add another 3/2 valve creating AND control.</p>	<b>Justification</b>	<p>To ensure the pool will not deepen too quickly/water will not splash over the side.</p> <p>The electrical actuators are less safe than pneumatic actuators where water is being used.</p> <p>Hands free sensor to control the circuit will be safer as there is no risk of electric shock.</p> <p>This is safer as there is less chance of the pool floor being lowered unexpectedly.</p>	2	<p>Descriptive response relating to pool safety.</p> <ul style="list-style-type: none"> <li>appropriate modification of the pneumatic circuit related to the operation of the pool floor. <b>(1 mark)</b></li> </ul> <p>Accept modification to the pneumatic circuit as either components or output relating to the raising/lowering of the pool floor.</p> <ul style="list-style-type: none"> <li>appropriate justification of the modification relating to safety. Apply FTE. <b>(1 mark)</b></li> </ul>
<b>Modification</b>	<p>Slow the lowering of the pool floor/by adding another unidirectional restrictor.</p> <p>Remove the use of electricity from the pneumatic circuit actuators/use a push button actuator instead of a solenoid actuator.</p> <p>Change the push button to a solenoid (to enable programmable control).</p> <p>Add another 3/2 valve creating AND control.</p>							
<b>Justification</b>	<p>To ensure the pool will not deepen too quickly/water will not splash over the side.</p> <p>The electrical actuators are less safe than pneumatic actuators where water is being used.</p> <p>Hands free sensor to control the circuit will be safer as there is no risk of electric shock.</p> <p>This is safer as there is less chance of the pool floor being lowered unexpectedly.</p>							

[END OF MARKING INSTRUCTIONS]